

A

B

C

D

REVISIONS

REV	DESCRIPTION	DATE	APPROVED
A	Released	7/2/2010	

4

4

Hardware Included
 6 X BOLTS
 12 X WASHERS
 12 X NUTS

Hardware Needed
 6 X BOLTS
 12 X WASHERS
 4 X NUTS

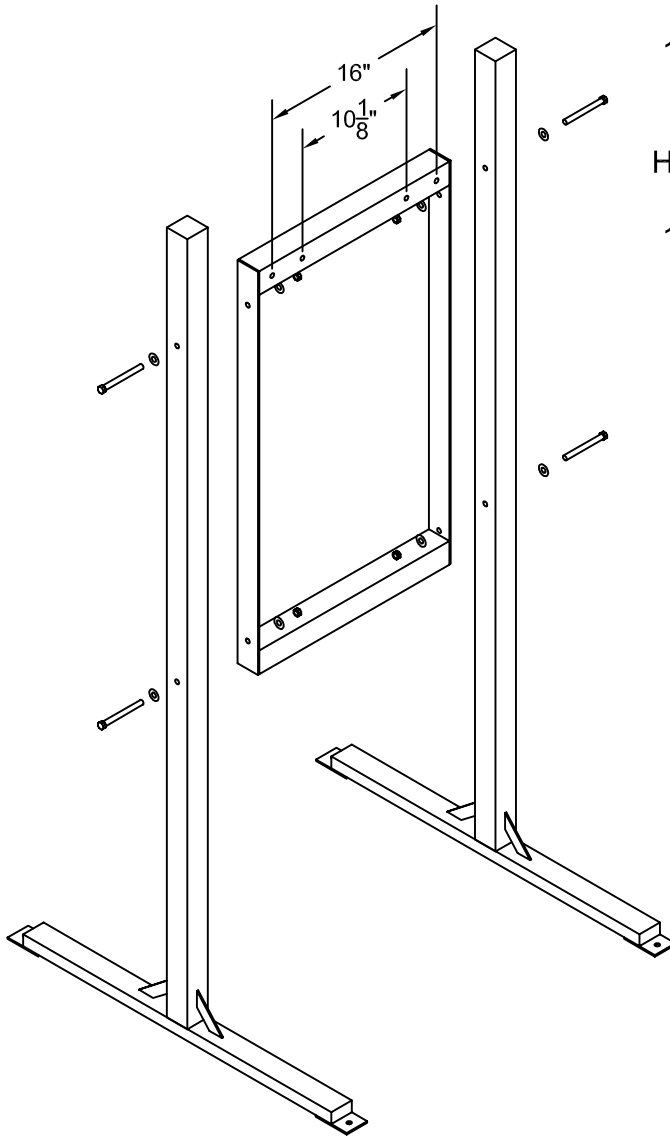

3

3

2

2

- Note 1: 4 HANGERS WITH ROD ARE PROVIDED, BUT NOT USED.
- Note 2: For GB142, DRILL TWO HOLES 16 ON CENTER IN TOP RAIL AND USE MOUNTING BRACKET PROVIDED WITH BOILER.
- Note 3: FOR GB162, PREDRILLED HOLES SPACED 10 $\frac{1}{8}$ "

1

1

Bosch Thermotechnology Corp.
 50 Wentworth Ave.
 Londonderry, NH 03053

Tolerance
 Fraction = $\pm \frac{1}{16}$ "
 x.x = ± 0.030
 x.xx = ± 0.015
 x.xxx = ± 0.005

This Drawing is the exclusive property of Bosch Thermotechnology Corporation, it may not be reproduced or given to third parties.

Drawn By:
 M SPIRIDIGLOZZI

Approved By:
 J MILLS



Bosch Thermotechnology Corp.

DESCRIPTION GB142/GB162 Assembly Stand			
SIZE A	SCALE NTS	DWG NO. BTC 435006104	REV A
DATE		SHEET 1 of 2	

A

B

C

D

A

B

C

D

REVISIONS

REV	DESCRIPTION	DATE	APPROVED
A	Released	7/2/2010	

4

4

Hardware Included
 6 X BOLTS
 12 X WASHERS
 10 X NUTS

Hardware Needed
 6 X BOLTS
 12 X WASHERS
 4 X NUTS

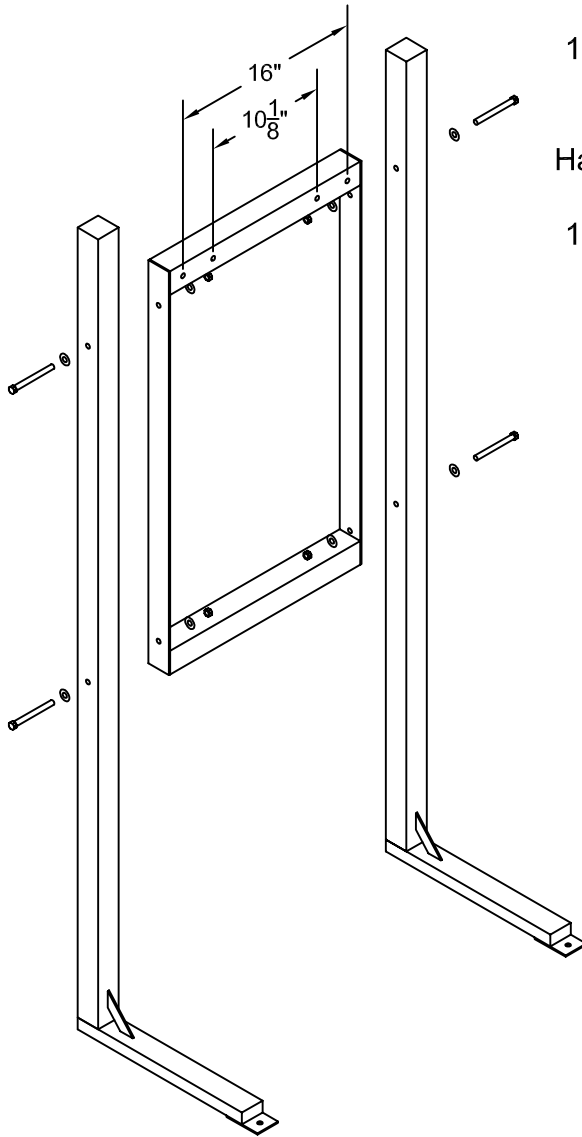

3

3

2

2

- Note 1: 4 HANGERS WITH ROD ARE PROVIDED, BUT NOT USED.
- Note 2: For GB142, DRILL TWO HOLES 16 ON CENTER IN TOP RAIL AND USE MOUNTING BRACKET PROVIDED WITH BOILER.
- Note 3: FOR GB162, PREDRILLED HOLES SPACED 10 1/8"

1

1

Bosch Thermotechnology Corp.
 50 Wentworth Ave.
 Londonderry, NH 03053

Tolerance
 Fraction = $\pm \frac{1}{16}$ "
 x.x = ± 0.030
 x.xx = ± 0.015
 x.xxx = ± 0.005

This Drawing is the exclusive property of Bosch Thermotechnology Corporation, it may not be reproduced or given to third parties.

Drawn By:
 M SPIRIDIGLOZZI

Approved By:
 J MILLS



Bosch Thermotechnology Corp.

DESCRIPTION GB142/GB162 Assembly Stand			
SIZE A	SCALE NTS	DWG NO. BTC 435006104	REV A
DATE		SHEET 2 of 2	

A

B

C

D