

INSTALLATION manual

Table of Contents

Model Nomenclature	1
Initial Inspection.....	2
General Description	2
Moving and Storage	2
Safety Considerations	2
Location.....	2
Installation.....	2
Condensate Drain.....	3
Duct System.....	3
Piping	3
Electrical	4
Thermostat Connections	4
Safety Devices & the UPM Controller.....	5
Electric Heater Package Option.....	6
Sequence of Operation Single Stage Units.....	7
Sequence of Operation Two-Stage Units	7
Well Water Systems	7
Installation of Pressure Regulating Valves	7
Cooling Tower / Boiler Application.....	7
Earth Coupled Systems.....	8
System Checkout.....	8
Unit Start-Up.....	8
Maintenance.....	8
Wiring Diagrams	9
Trouble Shooting	13
Unit Check Out.....	14
Operating Pressures & Temperatures.....	15

MODEL NOMENCLATURE

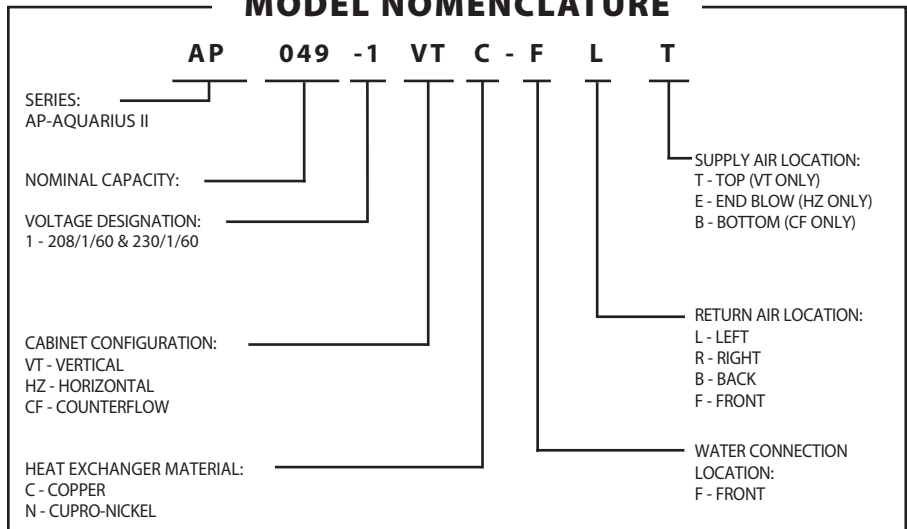

INITIAL INSPECTION:

Be certain to inspect all cartons or crates on each unit as received at the job site before signing the freight bill. Verify that all items have been received and that there are no visible damages; note any shortages or damages on all copies of the freight bill. In the event of damage or shortage, remember that the purchaser is responsible for filing the necessary claims with the carrier. Concealed damages not discovered until after removing the units from the packaging must be reported to the carrier within 24 hours of receipt.

GENERAL DESCRIPTION:

These Water-to-Air Heat Pumps provide the best combination of performance and efficiency available. Safety devices are built into each unit to provide the maximum system protection possible when properly installed and maintained.

The AP Water-to-Air Heat Pumps are Underwriters Laboratories (UL) and (cUL) listed for safety. The water-to-Air Heat Pumps are designed to operate with entering fluid temperature between 20°F to 80°F in the heating mode and between 50°F to 110°F in the cooling mode.

NOTE: 50°F Min. EWT for well water applications with sufficient water flow to prevent freezing. Antifreeze solution is required for all closed loop applications. Cooling Tower/Boiler and Earth Coupled (Geo Thermal) applications should have sufficient antifreeze solution to protect against extreme conditions and equipment failure. Frozen water coils are not covered under warranty.

NOTE: This product should not be used for temporarily heating/cooling during construction. Doing so may effect the units warranty.

MOVING AND STORAGE:

If the equipment is not needed for immediate installation upon its arrival at the job site, it should be left in its shipping carton and stored in a clean, dry area. Units must only be stored or moved in the normal upright position as indicated by the "UP" arrows on each carton at all times. If unit stacking is required, stack units as follows: Vertical units less than 6 tons, no more than two high. Horizontal units less than 6 tons, no more than three high. "Do not stack units larger than 6 tons."

SAFETY CONSIDERATIONS:

Installation and servicing of this equipment can be hazardous due to system pressure and electrical components. Only trained and qualified personnel should install, repair, or service the equipment. Untrained personnel can perform basic functions of maintenance such as cleaning coils and replacing filters.

WARNING: Before performing service or maintenance operations on the system, turn off main power to the unit. Electrical shock could cause personal injury or death.

When working on equipment, always observe precautions described in the literature, tags, and labels attached to the unit. Follow all safety codes. Wear safety glasses and work gloves. Use a quenching cloth for brazing, and place a fire extinguisher close to the work area.

LOCATION:

Locate the unit in an indoor area that allows easy removal of the filter and access panels, and has enough room for service personnel to perform maintenance or repair. Provide sufficient room to make fluid, electrical, and duct connection(s). If the unit is located in a confined space such as a closet, provisions must be made for return air to freely enter the space. On horizontal units, allow adequate room below the unit for a condensate drain trap and do not locate the unit above supply piping. These units are not approved for outdoor installation; therefore, they must be installed inside the structure being conditioned. Do not locate in areas that are subject to freezing.

INSTALLATION:

NOTE: Remove all shipping blocks under blower housing. Loosen compressor mounting bolts.

MOUNTING VERTICAL UNITS:

Vertical units up to six tons are available in left, right, front, or rear air return configurations. Vertical units should be mounted level on a vibration absorbing pad slightly larger than the base to minimize vibration transmission to the building structure. It is not necessary to anchor the unit to the floor. (See Figure #1).

MOUNTING HORIZONTAL UNITS:

While horizontal units may be installed on any level surface strong enough to hold their weight, they are typically suspended above a ceiling by threaded rods. The rods are usually attached to the unit corners by hanger bracket kits (P/N 930-004, 006). (See Figure #2). The rods must be securely anchored to the ceiling. Refer to the hanging bracket assembly and

installation instructions for details. Model AP025 requires four mounting brackets (P/N 930-004). Models AP035 thru AP071 require six brackets (930-006). (See unit horizontal detail drawing). Horizontal units installed above the ceiling must conform to all local codes. An auxiliary drain pan if required by code, should be at least four inches larger than

the bottom of the heat pump. Plumbing connected to the heat pump must not come in direct contact with joists, trusses, walls, etc.

Some applications require an attic floor installation of the horizontal unit. In this

case the unit should be set in a full size secondary drain pan on top of a vibration absorbing mesh. The secondary

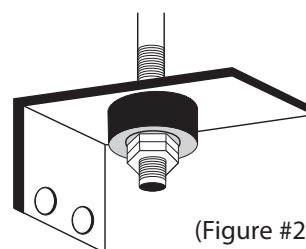
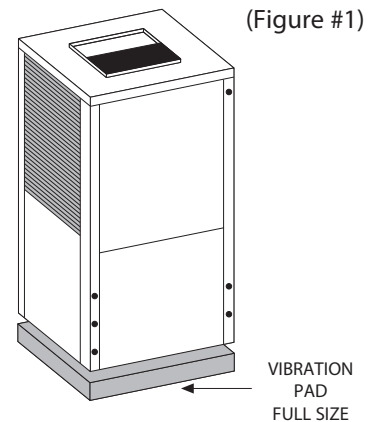

drain pan prevents possible condensate overflow or water leakage damage to the ceiling. The secondary drain pan is usually placed on a plywood base isolated from the ceiling joists by additional layers of vibration absorbing mesh. In both cases, a 3/4" drain connected to this secondary pan should be run to an eave at a location that will be noticeable. If the unit is located in a crawl space, the bottom of the unit must be at least 4" above grade to prevent flooding of the electrical parts due to heavy rains.

CONDENSATE DRAIN:

NOTE: If equipped with float style condensate overflow switch, final adjustment must be made in the field.

A drain line must be connected to the heat pump and pitched away from the unit a minimum of 1/8" per foot to allow the condensate to flow away from the unit.

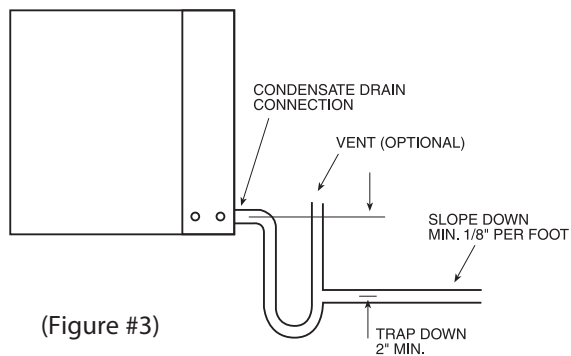

(Figure #3)

This connection must be in conformance with local plumbing codes. A trap must be installed in the condensate line to insure free condensate flow. (Heat Pumps are not internally trapped). A vertical air vent is sometimes required to avoid air pockets. (See Figure #3). The length of the trap depends on the amount of positive or negative pressure on the drain pan. A second trap must not be included.

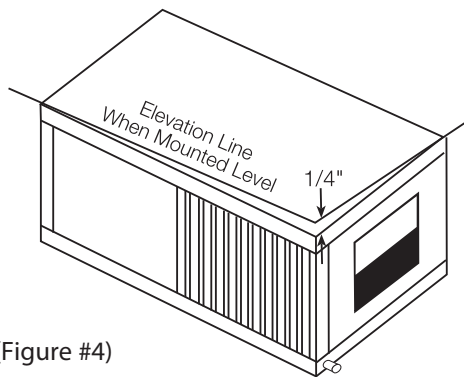

(Figure #4)

The horizontal unit should be pitched approximately 1/4" towards the drain in both directions, to facilitate condensate removal. (See Figure #4)

DUCT SYSTEM:

A supply air outlet collar and return air duct flange are provided on all units to facilitate duct connections. Refer to the FHP individual data specification sheet for physical dimensions of the collar and flange.

A flexible connector is recommended for supply and return air duct connections on metal duct systems. All metal ducting should be insulated with a minimum of one inch duct insulation to avoid heat loss or gain and prevent condensate forming during the cooling operation. Application of the unit to uninsulated duct work is not recommended as the unit's performance will be adversely affected. Do not connect discharge ducts directly to the blower outlet. The factory provided air filter must be removed when using a filter back return air grill. The factory filter should be left in place on a free return system.

If the unit will be installed in a new installation which includes new duct work, the installation should be designed using current ASHRAE procedures for duct sizing. If the unit is to be connected to existing ductwork, a check should be made to assure that the duct system has the capacity to handle the air required for the unit application. If the duct system is too small, larger ductwork should be installed. Check for existing leaks and repair.

The duct system and all diffusers should be sized to handle the designed air flow quietly. To maximize sound attenuation of the unit blower, the supply and return air plenums should be insulated. There should be no direct straight air path thru the return air grille into the heat pump. The return air inlet to the heat pump must have at least one 90 degree turn away from the space return air grille. If air noise or excessive air flow are a problem, the blower speed can be changed to a lower speed to reduce air flow. (Refer to ECM motor interface board section in this manual and Figure #7)

PIPING:

Supply and return piping must be as large as the unit connections on the heat pump (larger on long runs). Never use flexible hoses of a smaller inside diameter than that of the fluid connections on the unit. AP units are supplied with either a copper or optional cupro-nickel condenser. Copper is adequate for ground water that is not high in mineral content. Should your well driller express concern regarding the quality of the well water available or should any known hazards exist in your area, we recommend proper testing to assure the well water quality is suitable for use with water source equipment. In conditions anticipating moderate scale formation or in brackish water a cupro-nickel heat exchanger is recommended.

Both the supply and discharge water lines will sweat if subjected to low water temperature. These lines should be insulated to prevent damage from condensation.

All manual flow valves used in the system must be ball valves. Globe and gate valves must not be used due to high pressure drop and poor throttling characteristics. Never exceed the recommended water flow rates as serious damage or erosion of the water to refrigerant heat exchanger could occur.

Always check carefully for water leaks and repair appropriately. Units are equipped with female pipe thread fittings. Consult the specification sheets for sizes. Teflon tape sealer should be used when connecting water piping connections to the units to insure against leaks and possible heat exchanger fouling. Do not overtighten the

connections. Flexible hoses should be used between the unit and the rigid system to avoid possible vibration. Ball valves should be installed in the supply and return lines for unit isolation and unit water flow balancing.

ELECTRICAL:

(Refer to electrical component box layout, Figure #5)

Field wiring must comply with local and national electric codes. Power to the unit must be within the operating voltage range indicated on the unit nameplate or on the performance data sheet. On three phase units (single stage units only) phases must be balanced within 2%.

CAUTION: Operation of unit on improper line voltage or with excessive phase imbalance will be hazardous to the unit, constitutes abuse and may void the warranty.

Properly sized fuses or HACR circuit breakers must be installed for branch circuit protection. See unit nameplate for maximum fuse or breaker size.

The unit is provided with a concentric knock-out in the front left corner post for attaching common trade sizes of conduit, route power supply wiring through this opening. Always connect the ground lead to the grounding lug provided in the control box and power leads to the power supply terminal block as indicated on the wiring diagram and Figure #5.

(Figure #5)
Electrical Box Component Layout

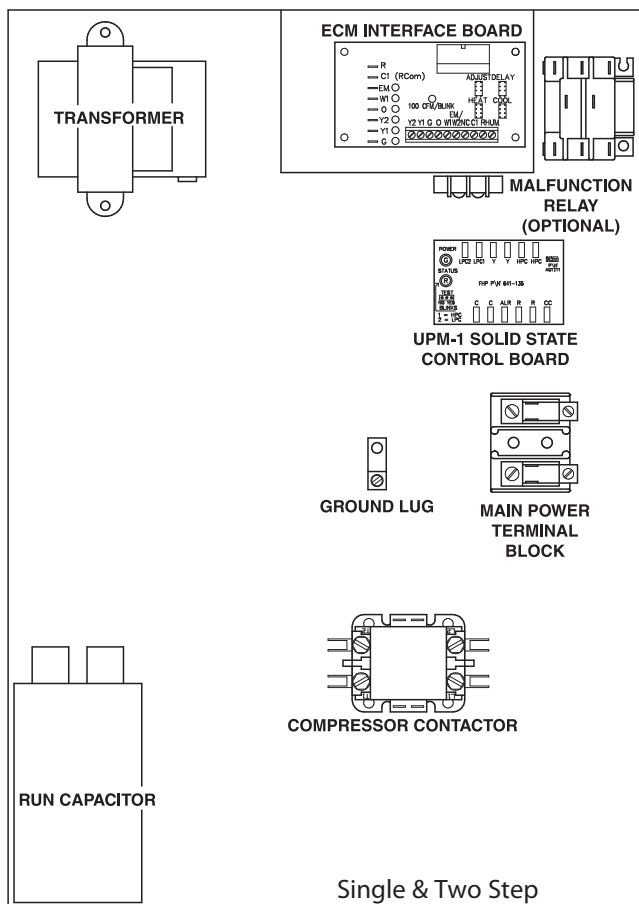

NOTE: Units supplied with internal electric heat require two (2) separate power supplies: one for the unit compressor and one for the electric heater elements, blower motor and control circuit. Refer to the ELECTRIC HEATER PACKAGE OPTION section and Figure #9 for wiring instructions, minimum circuit ampacities and maximum fuse/breaker sizing.

ECM INTERFACE BOARD:

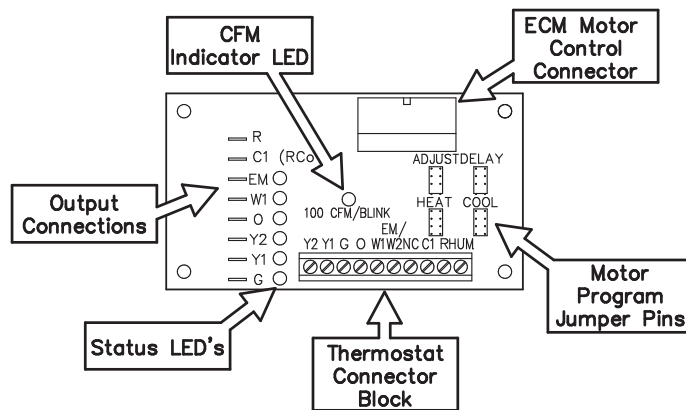

(Figure #6)

THERMOSTAT CONNECTIONS:

Thermostat wiring is connected to the 10 pin screw type terminal block on the lower center portion of the ECM Interface Board. In addition to providing a connecting point for thermostat wiring, the interface board also translates thermostat inputs into control commands for the variable speed programmable ECM DC fan motor and displays an LED indication of operating status. The thermostat connections and their functions are as follows:

- Y2 Second Stage Compressor Operation
- Y1 First Stage Compressor Operation
- G Fan
- O Reversing Valve (energized in cooling)
- W1 Auxiliary Electric Heat (runs in conjunction with compressor)
- EM/W2 Emergency Heat (electric heat only)
- NC Transformer 24 VAC Common (extra connection)
- C1 Transformer 24 VAC Common (primary connection)
- R Transformer 24 VAC Hot
- HUM Dehumidification Mode

If the unit is being connected to a thermostat with a malfunction light, this connection is made at the unit malfunction output or relay.

NOTE: If the thermostat is provided with a malfunction light powered off of the common (C) side of the transformer, the unit must be provided with a malfunction relay (FHP option # 660-006) to properly energize the light. The relay coil will be wired across the (ALR) and (C) contacts on the unit's UPM board and the relay's normally open contacts across (ALR) and the malfunction light connection on the thermostat. If the thermostat is provided with a malfunction light powered off of the hot (R) side of the transformer, then the thermostat malfunction light connection should be connected directly to the (ALR) contact on the unit's UPM board.

NOTE: Do not set the ADJ jumper to the (-) setting when electric heaters are installed. Doing so may cause the heaters to cycle on their thermal overload switches, potentially shortening the life of the switches.

The other three sets of jumper pins are used to select the proper program in the ECM motor for the unit. Refer to Figure #7 for the proper jumper placement.

NOTE: Always disconnect power before changing jumper positions on the interface board and reset the unit afterward.

MOTOR PROFILE AIR FLOW TABLE CFM								
TWO STAGE UNITS								
MODEL	FAN ONLY	Y1 COOL/HEAT	Y2 COOL/HEAT	AUX. HEAT	EMERG. HEAT	PLUS ADJ	MINUS ADJ	TAP COOL/HEAT/DELAY
AP025	600	750	950	950	950	1090	800	A
AP035	900	1000	1200	1200	1200	1400	1000	A
AP049	1200	1300	1700	1700	1700	1950	1450	B
AP061	1300	1500	2000	2000	2000	2100	1900	A
AP071	1300	1500	2100	2100	2100	2300	1900	A

(Figure #7)

To the left of the thermostat connection block are a row of 2 red and 4 green LED's. These LED's indicate the operating status of the unit. They are labeled as follows:

- EM (red) Emergency Heat On
- W1 (red) Auxiliary Heat On
- O (green) Reversing Valve Energized, unit is in cooling mode
- Y2 (green) Second Stage Compressor On
- Y1 (green) First Stage Compressor On
- G (green) Fan On

Just above the connector block is a single red LED labeled CFM that will blink intermittently when the unit is running and may flicker when the unit is off. This LED indicates the air delivery of the blower at any given time. Each blink of the LED represent 100 CFM of air delivery so if the LED blinks 12 times, pauses, blinks 12 times, etc. the blower is delivering 1200 CFM. Refer to Figure #7 for factory programmed air delivery settings for the ES Series.

To the right of the thermostat connection block is a green LED labeled dehumidify.

Just above and to the right of the thermostat connection block are four sets of jumper pins labeled ADJ, DELAY, HEAT and COOL. The ADJ set of pins are labeled NORM, (+), (-) and TEST. AP units will all be set on the NORM position from the factory, however, airflow can be increased (+) or decreased (-) by 15% from the pre-programmed setting by relocating the jumper in this section. The TEST position is used to verify proper motor operation. If a motor problem is suspected, move the ADJ jumper to the TEST position and energize G on the thermostat connection block. If the motor ramps up to 100% power, then the motor itself is functioning normally. Always remember to replace the jumper to NORM, (+) or (-) after testing and reset the unit thermostat to restore normal operation.

To the left of the red and green status LED's is a row of 1/4" male quick connects. These are used to pass thermostat inputs on to the rest of the control circuit. Remember to always turn off unit power at the circuit breaker before attaching or disconnecting any wiring from these connections to avoid accidental short circuits that can damage unit control components.

SAFETY DEVICES AND THE UPM CONTROLLER

Each unit is factory provided with a Unit Protection Module (UPM) that controls the compressor operation and monitors the safety controls that protect the unit.

Safety controls include the following:

- High pressure switch located in the refrigerant discharge line and wired across the HPC terminals on the UPM
- Low pressure switch located in the unit refrigerant suction line and wired across terminals LPC1 and LPC2 on the UPM.
- Optional freeze protection sensor located on the leaving side of the water coil prevents unit operation below 35° F. A freeze stat pin located on the board may be put in the YES or NO position depending whether the freeze stat is ordered.

NOTE: The factory default is in the YES position. If the freeze stat option is not ordered the pin must be relocated to the NO position.

- Optional Condensate overflow protection sensor located in the drain pan of the unit and connected to the 'cond' terminal on the UPM board.

The UPM includes the following features:

- **ANTI-SHORT CYCLE TIMER** – 5 minute delay on break timer to prevent compressor short cycling.
- **RANDOM START** – Each controller has a unique random start delay ranging from 270 to 300 seconds.
- **LOW PRESSURE BYPASS TIMER** - The low pressure switch is bypassed for 120 seconds after compressor start-up to prevent nuisance low pressure lockouts during cold start-up in the heating mode.
- **BROWNOUT/SURGE/POWER INTERRUPTION PROTECTION** – a 20 millisecond window is monitored for the above condition. Should any of these conditions be detected,

the 5-minute delay on break timer and the random start timer delay are initiated.

- **MALFUNCTION OUTPUT** – The controller has a set of wet contacts for remote fault indication.
- **TEST SERVICE PIN** – A jumper pin is provided to reduce all time delay settings to 5 seconds during troubleshooting or verification of unit operation. Note that operation of the unit in test mode can lead to accelerated wear and premature failure of the unit.
- **L.E.D. FAULT INDICATION** – Two L.E.D. indicators are provided:
- **GREEN:** Power L.E.D. indicates 18 – 30 VAC present at the board.
- **RED:** Fault indicator with blink codes as follows:
 - **ONE BLINK** High pressure lockout
 - **TWO BLINKS** Low pressure lockout
 - **THREE BLINKS** Freeze sensor lockout
 - **FOUR BLINKS** Condensate overflow
 - **FIVE BLINKS** Brown out

The fault pulse code may be sent to the ALR fault terminal by placing the Alarm Output pin in the pulse position. The pulse signal may be sent to a thermostat with a fault indication LED (24v) and will display the fault code on the thermostat.
- **INTELLIGENT RESET** - If a fault condition is initiated the 5 minute delay on break time period and the random start timer are initiated and the unit will restart after these delays expire. During this period the fault LED will indicate the cause of the fault. If the fault condition still exists or reoccurs before 60 minutes, the unit will

go into a hard lockout and requires a manual lockout reset. A condensate overflow fault will cause the unit to go into a hard lockout immediately.

- **LOCKOUT RESET** - A hard lockout can be reset by turning the unit thermostat off and then back on or by shutting off unit power at the circuit breaker.

NOTE: The blower motor will remain active during a lockout condition.

ELECTRIC HEATER PACKAGE OPTION:

Factory or field installed internal electric heater packages are available for all Aquarius II series units. Two power supplies are required when heater packages are utilized. The power supply for the heater package (located in the electric heater package control box) provides power for the heater elements, the blower motor and the control circuit for the unit. The power supply for the unit provides power for the compressor. This allows the electric heaters to continue to operate along with the blower motor in the case of unit compressor and/or compressor power supply failure. See HP Series Heater Kit Instructions for field installation.

Each Aquarius II model has a number of heater sizes available. Refer to Figure #9 for heater package compatibility with specific Aquarius II units, model nomenclature and electrical data.

SEQUENCE OF OPERATION-TWO STAGE UNITS:

(Figure #13 Wire Schematic)

COOLING MODE:

Energizing the “O” terminal energizes the unit reversing valve in the cooling mode. The fan motor starts when the “G” terminal is energized. Note that the fan motor will take

(Figure #9)

AQUARIUS II MODEL	HEATER MODEL	KW	HEATER AMPS		CIRCUIT	MCA		MAX FUSE		AWG MIN
			208V	240V		208V	240V	208V	240V	
○ AP025 thru 035	HP050-1XS	4.8	17.3	20.0	L1/L2	27.1	30.4	30	30	8
○ AP049 thru 071	HP050-1XM	4.8	17.3	20.0	L1/L2	27.1	30.4	30	30	8
○ AP025 thru 035	HP075-1XS	7.2	23.6	30.0	L1/L2	34.9	42.9	40	45	8
○ AP049 thru 071	HP075-1XM	7.2	23.6	30.0	L1/L2	35.7	43.8	40	45	8
○ AP025 thru 035	HP100-1XS	9.6	34.7	40.0	L1/L2	48.8	55.4	50	60	6
○ AP049 thru 071	HP100-1XM	9.6	34.7	40.0	L1/L2	49.5	56.3	50	60	6
○ AP049 thru 071	HP150-1XM	14.4	52.0	60.0	SINGLE	71.2	81.3	80	90	4
	HP150-1XM	14.4	34.7	40.0	L1/L2	49.5	56.3	60	60	6
			17.3	20.0	L3/L4	21.7	25.0	25	25	10
○ AP049 thru 071	HP200-1XM	19.2	69.3	80.0	SINGLE	92.9	106.3	100	110	2
	HP200-1XM	19.2	34.7	40.0	L1/L2	49.5	56.3	50	60	6
			34.7	40.0	L3/L4	43.4	50.0	45	50	6

All heaters rated single phase 60 Hz, and include unit fan load. All fuses type “D” time delay or HACR type breaker or HRC FORM 1 Wire size based on 60 deg. C copper conductors.

30 seconds to ramp up to operating speed and will run at fan only rated air flow as long as there is no call for compressor or heater operation.

When the thermostat calls for first stage cooling (Y1) the loop pump or solenoid valve if present is energized and the first stage of compressor capacity starts. The fan ramps up to first stage cooling air flow in 30 seconds.

When the thermostat calls for second stage cooling (Y2) the second stage (or full compressor capacity) is initiated. The fan ramps up to full cooling air flow.

Once the thermostat is satisfied, the compressor shuts down accordingly and the fan ramps down to either fan only mode or off over a span of 30 seconds.

Note that a fault condition initiating a lockout will de-energize the compressor irrespective of which stage is engaged.

HEATING MODE:

The first two stages of heating (Y1 & Y2) operate in the same manner as cooling, but with the reversing valve de-energized. On a call for auxiliary heat (W1), the fan ramps up to auxiliary heat air flow immediately and the electric heater package is energized along with the compressor. As the thermostat is satisfied, the heaters will shut off as soon as W1 is de-energized, and the compressors will remain on until the thermostat stages are satisfied. Note that if the unit compressor lock out for any reason at this time, the electric heaters will continue to function normally.

Once the thermostat is satisfied, the compressor shuts down and the fan ramps down either fan only mode or off over a span of 30 seconds. If emergency heat (W2/EM) is called for, the fan will ramp up to emergency heat air flow immediately and the heater package will energize in emergency heat mode, all heater elements coming on. On shut down the fan will ramp down over a period of 30 seconds.

WELL WATER SYSTEMS:

(Figure #10)

Copper is adequate for ground water that is not high in mineral content. Should your well driller express concern regarding the quality of the well water available or should any known hazards exist in your area, we recommend proper testing to assure the well water quality is suitable for use with water source equipment. In conditions anticipating moderate scale formation or in brackish water a cupro-nickel heat exchanger is recommended. In well water applications water pressure must always be maintained in the heat exchanger. This can be accomplished with either control valve or a bladder type expansion tank. When using a single water well to supply both domestic water and the heat pump care must be taken to insure that the well can provide sufficient flow for both. In well water applications a slow closing solenoid valve must be used to prevent water hammer.

Solenoid valves should be connected across Y1 and C1 on the interface board for all. Make sure that the VA draw of the valve does not exceed the contact rating of the thermostat.

INSTALLATION OF PRESSURE REGULATING VALVES:

Pressure regulating valves are used to increase or decrease water flow through the heat pump in response to refrigerant pressure. In some cases more water may be required in heating than in cooling, or vice versa. With the Aquarius II heat pumps these valves are not required. However, if installed, a pair of valves are required for proper operation, one valve for cooling (direct acting) and another valve for heating (indirect acting). A refrigerant tap is provided in the refrigerant line located between the reversing valve and the water-to-refrigerant heat exchanger for proper monitoring of the refrigerant pressures.

The discharge water from the heat pump is not contaminated in any manner and can be disposed of in various ways depending on local building codes (i.e. discharge well, dry well, storm sewer, drain field, stream or pond, etc.) Most local codes forbid the use of a sanitary sewer for disposal. Consult your local building and zoning department to insure compliance in your area.

COOLING TOWER/BOILER SYSTEMS:

(Figure #11)

The cooling tower and boiler water loop temperature is usually maintained between 50° F to 100 ° F to assure adequate cooling and heating performance.

In the cooling mode, heat is rejected from the FHP unit into the water loop. A cooling tower provides evaporative cooling to the loop water thus maintaining a constant supply temperature to the unit. When utilizing open cooling towers, chemical water treatment is mandatory to ensure the water is free from corrosive elements. A secondary heat exchanger (plate frame) between the unit and the open cooling tower may also be used. It is imperative that all air be eliminated from the closed loop side of the heat exchanger to insure against fouling.

In the heating mode, heat is absorbed from the water loop. A boiler can be utilized to maintain the loop at the desired temperature.

CAUTION: Water piping exposed to extreme low ambient temperatures is subject to freezing.

Consult the specification sheets for piping sizes. Teflon tape sealer should be used when connecting to the unit to insure against leaks and possible heat exchanger fouling. Do not overtighten the connections. Flexible hoses should be used between the unit and the rigid system to avoid possible vibration. Ball valves should be installed in the supply and return lines for unit isolation and unit water flow balancing. Pressure/temperature ports are recommended in both supply and return lines for system flow balancing. Water flow can be accurately set by measuring the water-to-refrigerant heat exchangers water side pressure drop. See specification sheets for water flow vs. pressure drop information.

No unit should be connected to the supply or return piping until the water system has been completely cleaned and flushed to remove any dirt, piping chips or other foreign

material. Supply and return hoses should be connected together during this process to ensure the entire system is properly flushed. After the cleaning and flushing has taken place the unit may be connected to the water loop and should have all valves wide open.

EARTH COUPLED SYSTEMS:

(Figure #12)

Closed loop and pond applications require specialized design knowledge. No attempt at these installations should be made unless the dealer has received specialized training. Utilizing FHP's Ground Loop Pumping Package (GLP), makes the installation easy. Anti-freeze solutions are utilized when low evaporating conditions are expected to occur. Refer to the GLP installation manuals for more specific instructions.

SYSTEM CHECKOUT:

- After completing the installation, and before energizing the unit, the following system checks should be made:
- Verify that the supply voltage to the heat pump is in accordance with the nameplate ratings.
- Make sure that all electrical connections are tight and secure.
- Check the electrical fusing and wiring for the correct size.
- Verify that the low voltage wiring between the thermostat and the unit is correct.
- Verify that the water piping is complete and correct.
- Check that the water flow is correct, and adjust if necessary.
- Check the blower for free rotation, and that it is secured to the shaft.
- Verify that vibration isolation has been provided.
- Unit is serviceable. Be certain that all access panels are secured in place.

UNIT START-UP:

1. Set the thermostat to the highest setting.
2. Set the thermostat system switch to "COOL", and the fan switch to the "AUTO" position. The reversing valve solenoid should energize. The compressor and fan should not run.
3. Reduce the thermostat setting approximately 5 degrees below the room temperature.
4. Verify the heat pump is operating in the cooling mode.
5. Turn the thermostat system switch to the "OFF" position. The unit should stop running and the reversing valve should deenergize.
6. Leave the unit off for approximately (5) minutes to allow for system equalization.
7. Turn the thermostat to the lowest setting.
8. Set the thermostat switch to "HEAT".

9. Increase the thermostat setting approximately 5 degrees above the room temperature.
10. Verify the heat pump is operating in the heating mode.
11. Set the thermostat to maintain the desired space temperature.
12. Check for vibrations, leaks, etc...

MAINTENANCE:

1. Filter changes or cleanings are required at regular intervals. The time period between filter changes will depend upon type of environment the equipment is used in. In a single family home, that is not under construction, changing or cleaning the filter every 60 days is sufficient. In other applications such as motels, where daily vacuuming produces a large amount of lint, filter changes may be need to be as frequent as biweekly.

WARNING: Equipment should never be used during construction due to likelihood of wall board dust accumulation in the air coil of the equipment which permanently affects the performance and may shorten the life of the equipment.

2. An annual "checkup" is recommended by a licensed refrigeration mechanic. Recording the performance measurements of volts, amps, and water temperature differences (both heating and cooling) is recommended. This data should be compared to the information on the unit's data plate and the data taken at the original startup of the equipment.
3. Lubrication of the blower motor is not required, however may be performed on some motors to extend motor life. Use SAE-20 non-detergent electric motor oil.
4. The condensate drain should be checked annually by cleaning and flushing to insure proper drainage.
5. Periodic lockouts almost always are caused by air or water flow problems. The lockout (shutdown) of the unit is a normal protective measure in the design of the equipment. If continual lockouts occur call a mechanic immediately and have them check for: water flow problems, water temperature problems, air flow problems or air temperature problems. Use of the pressure and temperature charts for the unit may be required to properly determine the cause.

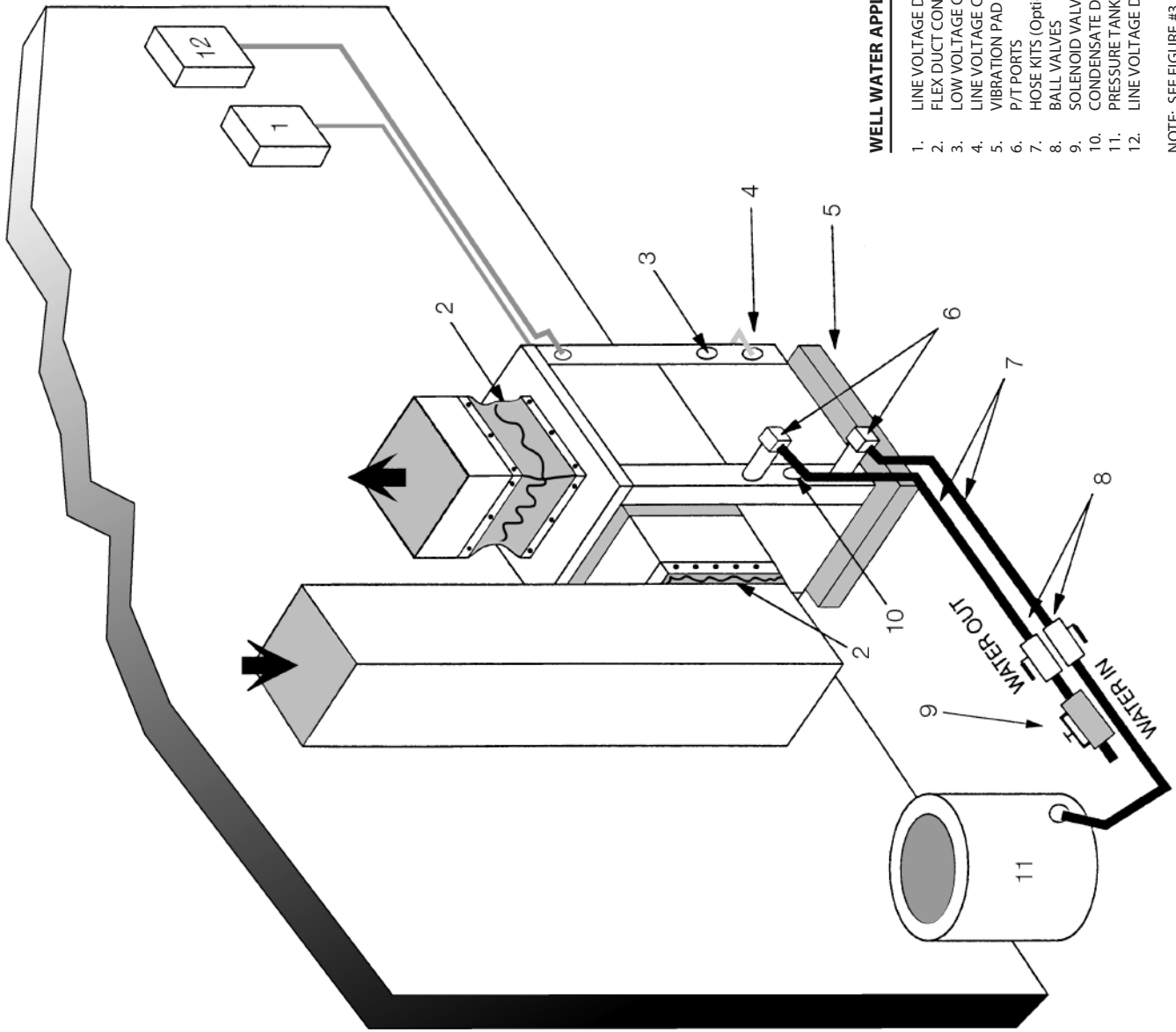

WELL WATER APPLICATIONS (50°F EWT MIN.)

- 1. LINE VOLTAGE DISCONNECT (UNIT)
- 2. FLEX DUCT CONNECTION
- 3. LOW VOLTAGE CONTROL CONNECTION
- 4. LINE VOLTAGE CONNECTION
- 5. VIBRATION PAD
- 6. P/T PORTS
- 7. HOSE KITS (Optional)
- 8. BALL VALVES
- 9. SOLENOID VALVE SLOW CLOSING
- 10. CONDENSATE DRAIN CONNECTION
- 11. PRESSURE TANK (Optional)
- 12. LINE VOLTAGE DISCONNECT (ELECTRIC HEATER)

NOTE: SEE FIGURE #3 FOR CONDENSATE DRAIN CONNECTION

(Figure #10)

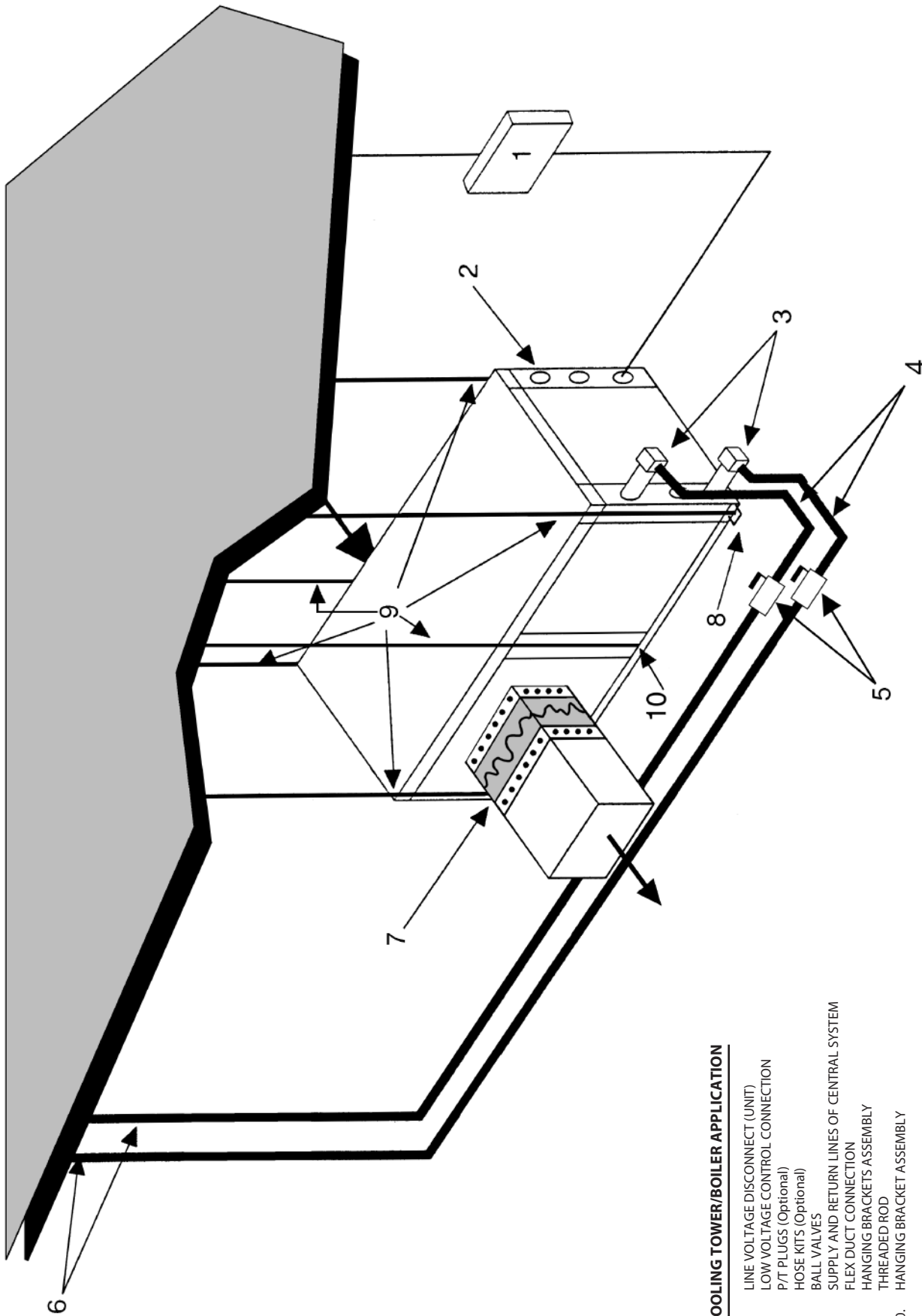

(Figure #11)

COOLING TOWER/BOILER APPLICATION

- 1. LINE VOLTAGE DISCONNECT (UNIT)
- 2. LOW VOLTAGE CONTROL CONNECTION
- 3. P/T PLUGS (Optional)
- 4. HOSE KITS (Optional)
- 5. BALL VALVES
- 6. SUPPLY AND RETURN LINES OF CENTRAL SYSTEM
- 7. FLEX DUCT CONNECTION
- 8. HANGING BRACKETS ASSEMBLY
- 9. THREADED ROD
- 10. HANGING BRACKET ASSEMBLY

NOTE: SEE FIGURE #3 FOR CONDENSATE DRAIN CONNECTION

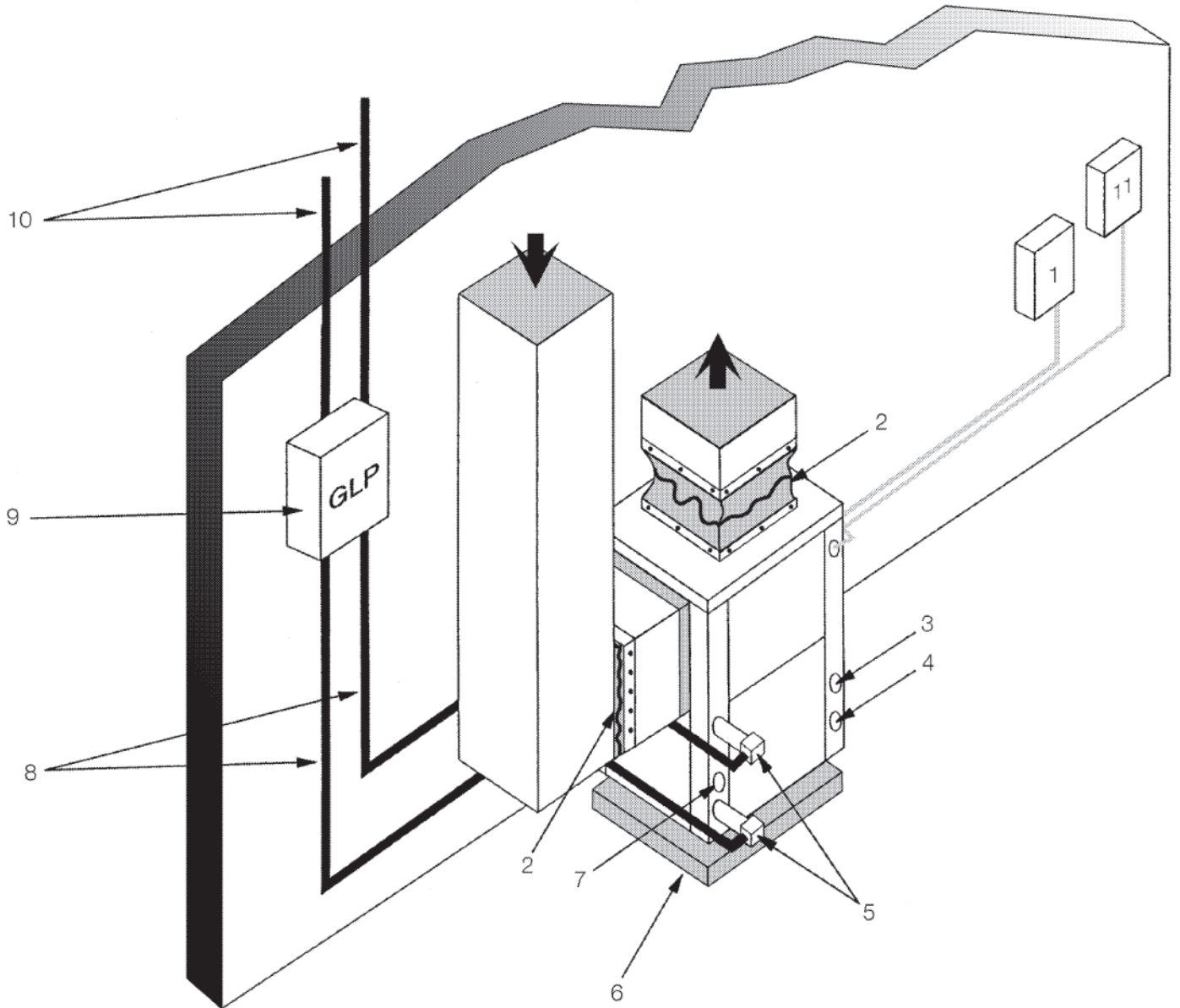

EARTH COUPLED APPLICATION

- 1. LINE VOLTAGE DISCONNECT (UNIT)
- 2. FLEX DUCT CONNECTION
- 3. LOW VOLTAGE CONTROL CONNECTION
- 4. LINE VOLTAGE CONNECTION (UNIT)
- 5. P/T PORTS
- 6. VIBRATION PAD
- 7. CONDENSATE DRAIN
- 8. GROUND LOOP CONNECTION KIT (555-000,001)
- 9. GROUND LOOP PUMPING PACKAGE (GL001-1 or 002-1)
- 10. POLYETHELENE WITH INSULATION
- 11. LINE VOLTAGE DISCONNECT (ELECTRIC HEATER)

NOTE: SEE FIGURE #3 FOR CONDENSATE DRAIN CONNECTION

(Figure #12)

CAUTION: UNIT CONTAINS TWO POWER SUPPLIES – INSURE BOTH SUPPLIES ARE OFF BEFORE SERVICING.

STATUS LED/ALARM BLINK CODES
1 HIGH PRESSURE FAULT
2 LOW PRESSURE FAULT
3 FREEZE SENSOR FAULT
4 CONDENSATE FAULT
5 BROWN OUT FAULT



STANDARD COMPONENTS LEGEND:

- BM – BLOWER MOTOR
- CAP – COMPRESSOR CAPACITOR
- CCH – COMPRESSOR CONTACTOR
- CCH – CRANKCS HTR (WHEN SUPPLIED)
- HPS – HIGH PRESSURE SWITCH
- LPS – LOW PRESSURE SWITCH
- PTCR – POS TEMP COEFF RESISTOR (WHEN SUPPLIED)
- RV – REVERSING VLV (HEAT PUMPS)
- Y2S – HIGH SPEED COMPRESSOR SOLENOID (ON COMPRESSOR)

OPTIONAL COMPONENTS LEGEND:

- [] AUX – AUXILIARY RELAY (FOR LOOP PUMP, ETC.)
- [] CADM – COMFORT ALERT DIAGNOSTICS MODULE
- [] CBR – 24V CRCT BRKR (75VA ONLY)
- [] CMFR – COMPRESSOR MALFUNCTION RELAY
- [] CMR – COMPRESSOR MONITOR RELAY
- [] CS – CONDENSATE SENSOR INSTALLED
- [] EMS – ENERGY MGMT SYSTEM RELAY
- [] FS – FREEZE SENSOR INSTALLED (NOTE 10)
- [] GLP – GROUND LOOP PUMP
- [] HP – HP SERIES ELECTRIC HTR PKG
- [] HRP – HEAT RECOVERY PACKAGE, INCLUDES: HRP M
- [] HRL – HEAT RECOVERY LIMIT (140 DEG)
- [] HWM – HOT WATER LIMIT (140 DEG)
- [] LGL – LOW GAS TEMPERATURE LIMIT
- [] SWT – ON/OFF SWITCH AND OVERLOAD

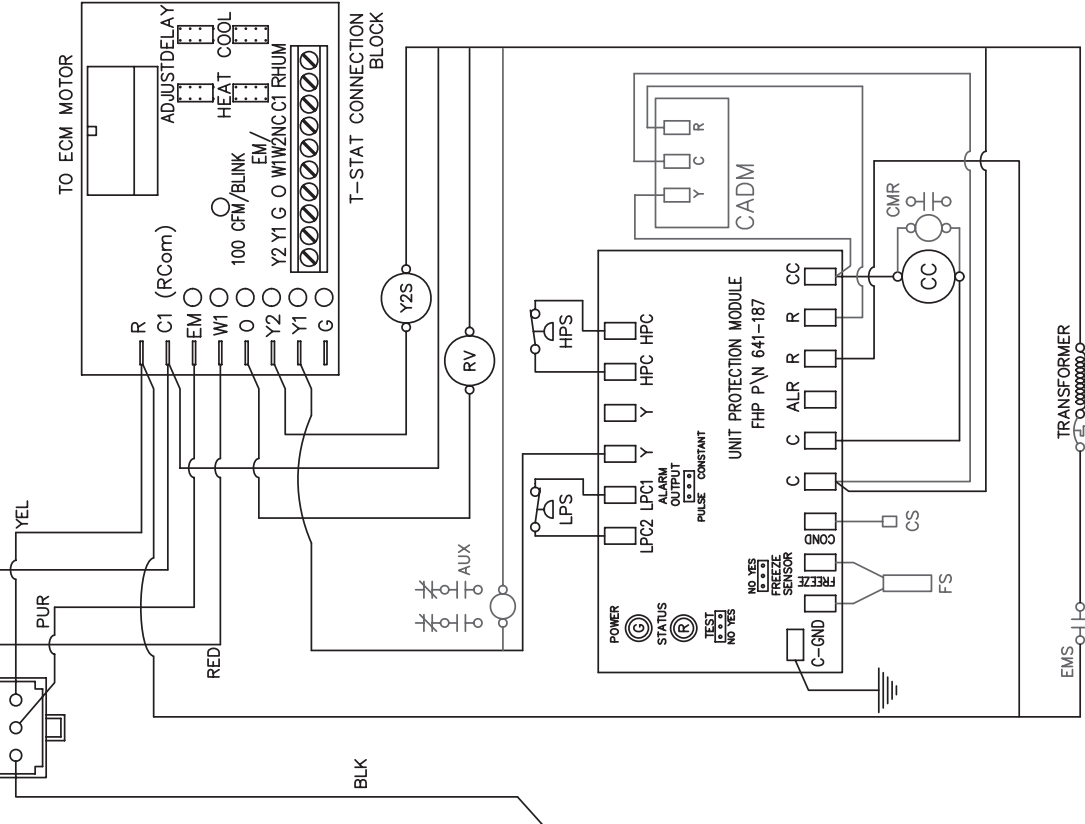
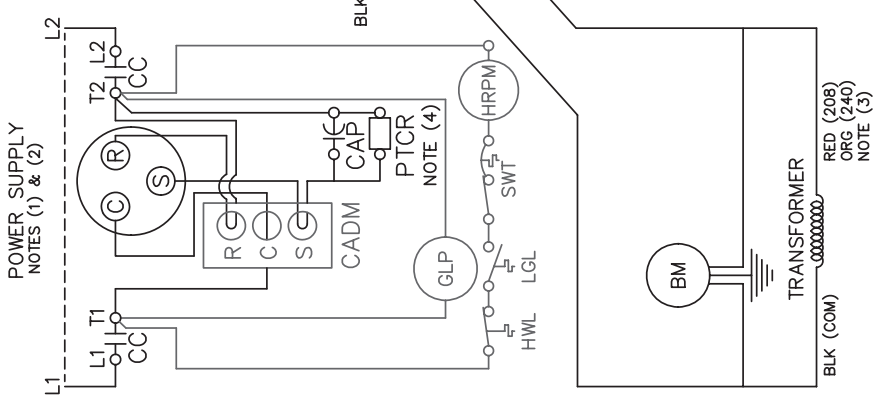

NOTES:

1. SEE UNIT NAME PLATE FOR ELECTRICAL RATING
2. ALL FIELD WIRING MUST BE IN ACCORDANCE WITH N.E.C.—N.F.P.A. #70 USE COPPER CONDUCTORS ONLY
3. 208/230V UNITS ARE FACTORY WIRED FOR 230V OPERATION. FOR 208V OPERATION, REMOVE ORG LEAD AND REPLACE WITH RED LEAD. CAP ALL UNUSED LEADS
4. PTCR IS STANDARD ON SELECT UNITS.
5. FOR ALTERNATE EMS COIL VOLTAGES CONSULT FACTORY.
6. UPM-1 INCLUDES BUILT IN: 30-60 SECOND RANDOM START 5 MINUTE DELAY ON BREAK 90 SECOND LOW PRESSURE BYPASS
7. "TEST" JUMPER PIN REDUCES DELAYS TO 5 SEC WHEN SET TO YES.
8. "FREEZE SENSOR" JUMPER PIN MUST BE SET TO NO IF FREEZE SENSOR IS NOT INSTALLED.
9. "ALARM OUTPUT" JUMPER PIN MUST BE SET TO PULSE IF BLINKING T-STAT SERVICE LIGHT IS DESIRED.

TYPICAL TWO STAGE WIRING DIAGRAM
SINGLE PHASE DIRECT DRIVE ECM BLOWER MOTOR
TWO STAGE WITH INTERNAL ELECTRIC HEAT
2 THROUGH 6 TON CAPACITY
WITH UPM-1

(Figure #13)

TROUBLE SHOOTING

PROBLEM	POSSIBLE CAUSE	CHECKS AND CORRECTIONS
ENTIRE UNIT DOES NOT RUN	Power supply off	Apply power, close disconnect
	Blown fuse	Replace fuse or reset circuit breaker. Check for correct fuses.
	Voltage supply low	If voltage is below minimum voltage specified on unit data plate, contact local power company.
	Thermostat	Set the fan to "ON", the fan should run. Set thermostat to "COOL" and lowest temperature setting, the unit should run in the cooling mode (reversing valve energized). Set unit to "HEAT" and the highest temperature setting, the unit should run in the heating mode. If neither the blower or compressor run in all three cases, the thermostat could be miswired or faulty. To ensure miswired or faulty thermostat verify 24 volts is available on the condensing section low voltage terminal strip between "R" and "C", "Y" and "C", and "O" and "C". If the blower does not operate, verify 24 volts between terminals "G" and "C" in the air handler. Replace the thermostat if defective.
BLOWER OPERATES BUT COMPRESSOR DOES NOT	Thermostat	Check setting, calibration, and wiring.
	Wiring	Check for loose or broken wires at compressor, capacitor, or contactor.
	Safety controls	Check UPM board red default L.E.D. for Blink Code
	Compressor overload open	If the compressor is cool and the overload will not reset, replace compressor.
	Compressor motor grounded	Internal winding grounded to the compressor shell. Replace compressor. If compressor burnout, install suction filter dryer.
	Compressor windings open	After compressor has cooled, check continuity of the compressor windings. If the windings are open, replace the compressor.
UNIT OFF ON HIGH PRESSURE CONTROL	Discharge pressure too high	In "COOLING" mode: Lack of or inadequate water flow. Entering water temperature too warm. Scaled or plugged condenser. In "HEATING" mode: Lack of or inadequate air flow. Blower inoperative, clogged filter or restrictions in ductwork.
	Refrigerant charge	The unit is overcharged with refrigerant. Reclaim refrigerant, evacuate and recharge with factory recommended charge.
	High pressure	Check for defective or improperly calibrated high pressure switch.
UNIT OFF ON LOW PRESSURE CONTROL	Suction pressure too low	In "COOLING" mode: Lack of or inadequate air flow. Entering air temperature too cold. Blower inoperative, clogged filter, or restrictions in ductwork. In "HEATING" mode: Lack of or inadequate water flow. Entering water temperature too cold. Scaled or plugged condenser.
	Refrigerant charge	The unit is low on refrigerant. Check for refrigerant leak, repair, evacuate and recharge with factory recommended charge.
	Low pressure switch	Check for defective or improperly calibrated low pressure switch.
UNIT SHORT CYCLES	Unit oversized	Recalculate heating and or cooling loads.
	Thermostat	Thermostat installed near a supply air grill, relocate thermostat. Readjust heat anticipator.
	Wiring and controls	Loose connections in the wiring or a defective compressor contactor.
INSUFFICIENT COOLING OR HEATING	Unit undersized	Recalculate heating and or cooling loads. If excessive, possibly adding insulation and shading will rectify the problem.
	Loss of conditioned air by leaks	Check for leaks in duct work or introduction of ambient air through doors or windows.
	Airflow	Lack of adequate air flow or improper distribution of air. Replace dirty filter.
	Refrigerant charge	Low on refrigerant charge causing inefficient operation.
	Compressor	Check for defective compressor. If discharge is too low and suction pressure is too high, compressor is not pumping properly. Replace compressor.
	Reversing valve	Defective reversing valve creating bypass of refrigerant from discharge to suction side of compressor. Replace reversing valve.
	Operating pressures	Compare unit operating pressures to the pressure / temperature chart for the unit.
	TXV	Check TXV for possible restriction or defect. Replace if necessary.
Moisture, noncondensables	The refrigerant system may be contaminated with moisture or noncondensables. Reclaim refrigerant, evacuate and recharge with factory recommended charge. Note: a liquid line dryer may be required.	

UNIT CHECK-OUT SHEET

Customer Data

Customer Name _____ Date _____
 Address _____
 Phone _____ Unit Number _____

Unit Nameplate Data

Unit Make _____
 Model Number _____ Serial Number _____
 Refrigerant Charge (oz) _____
 Compressor: RLA _____ LRA _____
 Blower Motor: FLA (or NPA) _____ HP _____
 Maximum Fuse Size (Amps) _____
 Minimum Circuit Ampacity (Amps) _____

Operating Conditions

	Cooling Mode	Heating Mode
Entering / Leaving Air Temp	_____ / _____	_____ / _____
Entering Air Measured at:	_____	_____
Leaving Air Measured at:	_____	_____
Entering / Leaving Fluid Temp	_____ / _____	_____ / _____
Fluid Flow (gpm)	_____	_____
Fluid Side Pressure Drop	_____	_____
Suction / Discharge Pressure (psig)	_____ / _____	_____ / _____
Suction / Discharge Temp	_____ / _____	_____ / _____
Suction Superheat	_____	_____
Entering TXV / Cap Tube Temp	_____	_____
Liquid Subcooling	_____	_____
Compressor Volts / Amps	_____ / _____	_____ / _____
Blower Motor Volts / Amps	_____ / _____	_____ / _____

Auxiliary Heat

Unit Make _____
 Model Number _____ Serial Number _____
 Max Fuse Size (Amps) _____
 Volts / Amps _____ / _____
 Entering Air Temperature _____
 Leaving Air Temperature _____

Operating Pressures & Temperatures Environmentally Safe R-410A Refrigerant

			OPERATING DATA							
			COOLING				HEATING			
MODEL	ENTERING WATER TEMP. °F	WATER FLOW GPM	SUCTION PRESSURE PSIG	DISCHARGE PRESSURE PSIG	WATER TEMP RISE °F	AIR TEMP DROP °F	SUCTION PRESSURE PSIG	DISCHARGE PRESSURE PSIG	WATER TEMP DROP °F	AIR TEMP RISE °F
AP025 Part Load	30°	4					75-91	264-322	5-6	15-17
		8					79-96	270-331	3-4	16-18
	40°	4	120-146	186-228	14-17	18-21	88-107	277-339	6-7	17-20
		8	115-140	175-214	8-9	19-23	92-112	284-348	4-5	18-21
	50°	4	129-157	218-267	14-17	18-20	98-122	291-356	7-8	20-23
		8	124-151	204-250	8-9	19-22	110-130	298-364	5-6	21-24
	60°	4	134-163	249-305	13-16	17-20	112-136	304-372	8-10	22-26
		8	128-156	233-287	8-9	18-21	117-143	312-381	6-7	23-28
	70°	4	138-168	281-341	13-16	17-19	124-152	318-389	9-11	24-29
		8	133-161	263-323	7-9	18-21	131-159	325-398	6-8	26-31
	80°	4	143-174	317-388	13-16	16-19	136-166	331-405	11-13	27-32
		8	137-167	297-366	7-9	17-20	143-174	339-415	7-9	28-33
	90°	4	147-179	357-437	13-16	16-18	149-181	345-422	12-14	29-35
		8	141-172	335-411	7-9	17-20	156-190	352-432	8-10	31-37
	100°	4	151-185	402-492	13-15	15-18				
		8	146-177	378-459	7-9	16-19				
AP025 Full Load	30°	4					76-92	242-297	3-4	13-14
		8					80-97	249-304	2-3	13-15
	40°	4	125-151	180-221	14-18	19-22	89-108	255-312	4-5	15-17
		8	120-146	169-207	8-10	20-23	93-113	261-320	3-3	16-18
	50°	4	134-163	211-258	14-18	18-21	106-118	267-327	5-6	17-19
		8	129-157	198-242	8-10	19-23	104-112	274-335	3-4	18-21
	60°	4	139-169	241-295	14-17	18-21	113-138	280-342	6-7	19-22
		8	134-163	227-278	8-10	19-22	119-145	287-351	4-5	20-23
	70°	4	144-175	272-333	14-17	17-20	126-155	292-358	7-8	21-24
		8	138-168	255-313	8-10	18-21	133-162	300-367	5-6	22-26
	80°	4	148-181	307-375	14-17	17-19	138-168	305-373	8-9	23-27
		8	143-174	288-353	8-10	18-21	145-177	312-382	5-6	24-29
	90°	4	153-186	346-423	14-17	16-19	151-184	317-388	8-10	25-29
		8	147-179	325-398	8-9	17-20	158-193	325-398	6-7	26-31
	100°	4	158-191	389-477	13-16	16-18				
		8	152-185	366-448	8-9	17-20				
AP035 Part Load	30°	4.5					73-89	266-325	5-6	15-18
		9.0					77-94	272-333	3-4	16-19
	40°	4.5	117-143	189-231	14-17	18-22	86-105	279-341	6-7	17-21
		9.0	112-137	178-217	8-9	19-24	90-110	286-350	4-5	18-22
	50°	4.5	126-154	221-270	14-17	18-21	105-125	293-358	7-8	20-24
		9.0	121-148	207-253	8-9	19-23	170-208	300-366	5-6	21-25
	60°	4.5	131-160	252-308	13-16	17-21	110-134	306-374	8-10	22-27
		9.0	125-153	237-290	8-9	18-22	115-141	314-383	6-7	23-29
	70°	4.5	135-165	284-347	13-16	17-20	122-150	320-391	9-11	24-30
		9.0	130-158	266-326	7-9	18-22	129-157	327-400	6-8	26-32
	80°	4.5	140-171	320-391	13-16	16-20	134-164	333-407	11-13	27-33
		9.0	134-164	300-367	7-9	17-21	141-172	341-417	7-9	28-35
	90°	4.5	144-176	360-440	13-16	16-19	147-179	347-424	12-14	29-36
		9.0	138-169	338-414	7-9	17-21	154-188	355-434	8-10	31-38
	100°	4.5	149-182	405-495	13-15	15-19				
		9.0	143-174	381-465	7-9	16-20				

This chart shows approximate temperatures and pressures for a unit in good repair. The values shown are meant as a guide only and should not be used to estimate system charge. This chart assumes rated air flow and 80° d.b./67° w.b. entering air temperature in cooling, 70° d.b. entering air temperature in heating. Heating data at entering fluid temperatures below 50° assumes the use of antifreeze.

As a result of continuing research and development, specifications are subject to change without notice.

Operating Pressures & Temperatures Environmentally Safe R-410A Refrigerant

			OPERATING DATA							
			COOLING				HEATING			
MODEL	ENTERING WATER TEMP. °F	WATER FLOW GPM	SUCTION PRESSURE PSIG	DISCHARGE PRESSURE PSIG	WATER TEMP RISE °F	AIR TEMP DROP °F	SUCTION PRESSURE PSIG	DISCHARGE PRESSURE PSIG	WATER TEMP DROP °F	AIR TEMP RISE °F
AP035 Full Load	30°	4.5					74-90	244-299	3-4	13-15
		9.0					78-95	251-306	2-3	13-16
	40°	4.5	122-149	183-224	14-18	19-23	87-106	257-314	4-5	15-18
		9.0	117-143	172-210	8-10	20-24	91-111	263-322	3-3	16-19
	50°	4.5	131-160	214-261	14-18	18-22	95-105	269-329	5-6	17-20
		9.0	126-154	201-245	8-10	19-24	100-125	276-337	3-4	18-22
	60°	4.5	136-166	244-298	14-17	18-22	111-136	282-344	6-7	19-23
		9.0	131-160	230-281	8-10	19-23	117-143	289-353	4-5	20-24
	70°	4.5	141-172	275-336	14-17	17-21	124-152	294-360	7-8	21-25
		9.0	135-165	258-316	8-10	18-22	131-160	302-369	5-6	22-27
	80°	4.5	145-178	310-378	14-17	17-20	136-166	307-375	8-9	23-28
		9.0	140-171	291-356	8-10	18-22	143-175	314-384	5-6	24-30
	90°	4.5	150-183	349-426	14-17	16-20	149-182	319-390	8-10	25-30
		9.0	144-176	328-401	8-9	17-21	156-191	327-400	6-7	26-32
	100°	4.5	155-189	392-480	13-16	16-19				
		9.0	149-182	369-451	8-9	17-21				
AP049 Part Load	30°	6.0					64-78	248-303	5-6	15-18
		12.0					67-82	254-311	3-4	16-19
	40°	6.0	109-134	183-224	18-22	19-23	75-91	261-319	6-8	17-21
		12.0	105-128	172-210	10-12	20-25	79-96	267-327	4-5	18-23
	50°	6.0	118-144	214-261	18-22	19-23	78-90	273-334	8-10	20-24
		12.0	113-138	201-245	10-12	20-24	82-95	280-342	5-7	21-26
	60°	6.0	122-149	244-298	17-21	18-22	96-117	286-349	9-11	22-27
		12.0	117-143	230-281	10-12	19-24	101-123	293-358	6-8	24-29
	70°	6.0	126-154	275-336	17-21	18-22	107-131	299-365	11-13	25-30
		12.0	121-148	258-316	10-12	19-23	113-138	306-374	7-9	26-32
	80°	6.0	130-159	310-378	17-21	17-21	117-143	311-380	12-15	27-33
		12.0	132-153	291-356	10-12	18-22	123-151	319-390	8-10	29-35
	90°	6.0	134-164	349-426	17-20	17-20	128-157	324-396	13-16	29-36
		12.0	129-158	328-401	9-12	18-22	135-165	332-406	9-11	31-38
	100°	6.0	139-170	392-480	16-20	16-20				
		12.0	133-163	369-451	9-11	17-21				
AP049 Full Load	30°	6.0					71-87	277-339	6-7	15-19
		12.0					75-92	284-347	4-5	16-20
	40°	6.0	118-144	194-237	21-25	19-23	84-102	291-356	7-9	18-22
		12.0	113-138	182-223	12-14	20-24	88-108	299-365	5-6	19-23
	50°	6.0	127-155	226-276	21-25	18-22	92-110	305-373	9-11	20-25
		12.0	122-149	213-260	12-14	19-24	98-120	313-383	6-7	21-26
	60°	6.0	131-160	259-316	21-25	18-22	108-132	320-391	10-13	23-28
		12.0	126-154	243-297	12-14	19-23	113-138	328-400	7-9	24-29
	70°	6.0	136-166	291-355	20-25	17-21	120-147	334-408	12-15	25-31
		12.0	130-159	273-334	12-14	18-22	126-154	342-418	8-10	27-32
	80°	6.0	140-171	328-401	20-24	17-20	131-161	348-425	14-17	27-34
		12.0	135-165	308-377	11-14	18-22	138-169	356-436	9-11	29-36
	90°	6.0	145-177	369-451	20-24	16-20	144-176	362-442	15-18	30-37
		12.0	139-170	347-424	11-14	17-21	151-185	371-453	10-12	32-39
	100°	6.0	149-183	415-508	19-24	16-19				
		12.0	143-175	391-477	11-14	17-21				

This chart shows approximate temperatures and pressures for a unit in good repair. The values shown are meant as a guide only and should not be used to estimate system charge. This chart assumes rated air flow and 80° d.b./67° w.b. entering air temperature in cooling, 70° d.b. entering air temperature in heating. Heating data at entering fluid temperatures below 50° assumes the use of antifreeze.

As a result of continuing research and development, specifications are subject to change without notice.

Operating Pressures & Temperatures Environmentally Safe R-410A Refrigerant

			OPERATING DATA							
			COOLING				HEATING			
MODEL	ENTERING WATER TEMP. °F	WATER FLOW GPM	SUCTION PRESSURE PSIG	DISCHARGE PRESSURE PSIG	WATER TEMP RISE °F	AIR TEMP DROP° F	SUCTION PRESSURE PSIG	DISCHARGE PRESSURE PSIG	WATER TEMP DROP °F	AIR TEMP RISE °F
AP061 Part Load	30°	7.0					68-84	256-313	5-7	19-23
		14.0					73-89	261-319	4-5	20-25
	40°	7.0	113-138	172-210	18-22	19-23	81-99	277-339	7-8	22-26
		14.0	110-134	161-196	12-14	20-24	86-105	283-346	5-6	23-28
	50°	7.0	116-142	206-252	17-21	19-23	93-114	299-365	8-9	24-29
		14.0	112-137	193-236	12-14	19-24	99-121	305-373	6-7	25-31
	60°	7.0	118-145	241-294	17-21	18-23	106-129	321-392	9-11	26-32
		14.0	115-140	225-275	11-14	19-23	113-138	327-400	7-8	28-34
	70°	7.0	121-148	275-336	17-21	18-22	118-145	342-418	10-12	29-35
		14.0	117-143	257-314	11-14	19-23	126-154	349-427	8-9	30-37
	80°	7.0	123-151	309-378	16-20	18-22	131-160	364-444	11-14	31-38
		14.0	120-146	289-353	11-13	19-23	139-170	371-454	8-10	33-40
	90°	7.0	126-154	344-420	16-20	18-22	143-175	385-471	12-15	33-41
		14.0	122-149	321-392	11-13	18-22	152-186	393-480	9-11	35-43
	100°	7.0	128-157	378-462	16-19	17-21				
		14.0	125-152	353-432	11-13	18-22				
AP061 Full Load	30°	7.0					68-84	256-313	5-7	19-23
		14.0					73-89	261-319	4-5	20-25
	40°	7.0	117-143	182-222	15-19	21-26	81-99	277-339	7-8	22-26
		14.0	114-139	170-208	11-14	22-27	86-105	283-346	5-6	23-28
	50°	7.0	120-147	215-263	15-18	20-25	93-114	299-365	8-9	24-29
		14.0	117-143	201-246	11-14	21-26	99-121	305-373	6-7	25-31
	60°	7.0	123-150	248-304	14-17	20-24	106-129	321-392	9-11	26-32
		14.0	119-146	232-284	11-13	21-25	113-138	327-400	7-8	28-34
	70°	7.0	126-154	282-344	14-17	19-24	118-145	342-418	10-12	29-35
		14.0	122-149	263-322	10-13	20-25	126-154	349-427	8-9	30-37
	80°	7.0	129-157	315-385	13-16	19-23	131-160	364-444	11-14	31-38
		14.0	125-153	294-360	10-12	19-24	139-170	371-454	8-10	33-40
	90°	7.0	132-161	348-426	13-16	18-22	143-175	385-471	12-15	33-41
		14.0	128-156	326-398	10-12	19-23	152-186	393-480	9-11	35-43
	100°	7.0	134-164	382-466	12-15	17-21				
		14.0	131-160	357-436	9-11	18-22				
AP071 Part Load	30°	9.0					71-87	259-316	5-7	19-23
		18.0					76-92	264-322	4-5	20-25
	40°	9.0	116-141	175-213	18-22	19-23	84-102	280-342	7-8	22-26
		18.0	113-137	164-199	12-14	20-24	89-108	286-349	5-6	23-28
	50°	9.0	119-145	209-255	17-21	19-23	96-117	302-368	8-9	24-29
		18.0	115-140	196-239	12-14	19-24	102-124	308-376	6-7	25-31
	60°	9.0	121-148	244-297	17-21	18-23	109-132	324-395	9-11	26-32
		18.0	118-143	228-278	11-14	19-23	116-141	330-403	7-8	28-34
	70°	9.0	124-151	278-339	17-21	18-22	121-148	345-421	10-12	29-35
		18.0	120-146	260-317	11-14	19-23	129-157	352-430	8-9	30-37
	80°	9.0	126-154	312-381	16-20	18-22	134-163	367-447	11-14	31-38
		18.0	123-149	292-356	11-13	19-23	142-173	374-457	8-10	33-40
	90°	9.0	129-157	347-423	16-20	18-22	146-178	388-474	12-15	33-41
		18.0	125-152	324-395	11-13	18-22	155-189	396-483	9-11	35-43
	100°	9.0	131-160	381-465	16-19	17-21				
		18.0	128-155	356-435	11-13	18-22				

This chart shows approximate temperatures and pressures for a unit in good repair. The values shown are meant as a guide only and should not be used to estimate system charge. This chart assumes rated air flow and 80° d.b./67° w.b. entering air temperature in cooling, 70° d.b. entering air temperature in heating. Heating data at entering fluid temperatures below 50° assumes the use of antifreeze.

As a result of continuing research and development, specifications are subject to change without notice.

Operating Pressures & Temperatures Environmentally Safe R-410A Refrigerant

			OPERATING DATA							
			COOLING				HEATING			
MODEL	ENTERING WATER TEMP. °F	WATER FLOW GPM	SUCTION PRESSURE PSIG	DISCHARGE PRESSURE PSIG	WATER TEMP RISE °F	AIR TEMP DROP °F	SUCTION PRESSURE PSIG	DISCHARGE PRESSURE PSIG	WATER TEMP DROP °F	AIR TEMP RISE °F
AP071 Full Load	30°	9.0					71-87	259-316	5-7	19-23
		18.0					76-92	264-322	4-5	20-25
	40°	9.0	120-146	185-225	15-19	21-26	84-102	280-342	7-8	22-26
		18.0	117-142	173-211	11-14	22-27	89-108	286-349	5-6	23-28
	50°	9.0	123-150	218-266	15-18	20-25	96-117	302-368	8-9	24-29
		18.0	120-146	204-249	11-14	21-26	102-124	308-376	6-7	25-31
	60°	9.0	126-153	251-307	14-17	20-24	109-132	324-395	9-11	26-32
		18.0	122-149	235-287	11-13	21-25	116-141	330-403	7-8	28-34
	70°	9.0	129-157	285-347	14-17	19-24	121-148	345-421	10-12	29-35
		18.0	125-152	266-325	10-13	20-25	129-157	352-430	8-9	30-37
	80°	9.0	132-160	318-388	13-16	19-23	134-163	367-447	11-14	31-38
		18.0	128-156	297-363	10-12	19-24	142-173	374-457	8-10	33-40
	90°	9.0	135-164	351-429	13-16	18-22	146-178	388-474	12-15	33-41
		18.0	131-159	329-401	10-12	19-23	155-189	396-483	9-11	35-43
	100°	9.0	137-167	385-469	12-15	17-21				
		18.0	134-163	360-439	9-11	18-22				

This chart shows approximate temperatures and pressures for a unit in good repair. The values shown are meant as a guide only and should not be used to estimate system charge. This chart assumes rated air flow and 80° d.b./67° w.b. entering air temperature in cooling, 70° d.b. entering air temperature in heating. Heating data at entering fluid temperatures below 50° assumes the use of antifreeze.

As a result of continuing research and development, specifications are subject to change without notice.

NOTES

