



COMMERCIAL | RT SERIES

## Energy Recovery Rooftop System

**RT** ROOFTOP  
**SERIES**

*Model RT series Rooftop WSHP incorporates an integral heat pump and energy recovery wheel to provide you with an economical, pre-engineered, high quality solution for 100 percent outdoor air applications traditionally requiring expensive, custom-built equipment.*



## Energy Recovery Rooftop System

Building design specifications require a certain amount of fresh air be delivered into the building. Introducing untreated air has the potential for creating uncontrolled conditions in the space resulting in conditions of high humidity with the resultant formation of mold which not only can create a sick building syndrome but can be prohibitively expensive to rectify. Without a heat recovery device energy in the exhaust air is lost increasing the operating cost significantly.

The RT series combines the benefits of the total energy wheel with supplemental heating and cooling by the water source heat pump. The result is a product that is specifically designed to process 100% outdoor air to desired supply conditions.

Four cabinet sizes provide air flow capacities from 1,000 cfm to 10,000 cfm with external static pressures up to 2.5 in. wg.

FHP RT series unit's built-in energy recovery wheel can recover 75% of the energy normally wasted through the exhausted air which is then used to condition the incoming supply air. This means savings of 3 to 4 tons of cooling and 50 – 60 MBH of heating for every 1,000 cfm of outdoor air depending on local climatic conditions.

Over 30 years of heat pump design experience lies behind the factory installed heat pump providing peace of mind and the knowledge that you will have a matched system. It also eliminates the cost and liability associated with field piping, charging and wiring by the contractor. A computer selection program simplifies unit selection and provides you several options to meet your specific requirements.

All this without having to pay a custom unit premium.

The result, reduced installation costs and increased energy savings over the life of the unit.

### Cooling

1. Outdoor air enters RT unit
2. The energy recovery wheel cools and dehumidifies outdoor air using energy from the exhaust airstream. Load is reduced by 3 to 4 tons per 1,000 cfm for many climates.
3. The heat pump provides supplemental cooling to further treat the outdoor air to desired supply conditions.
4. Optional reheat available to provide space neutral air.
5. Indoor space conditions

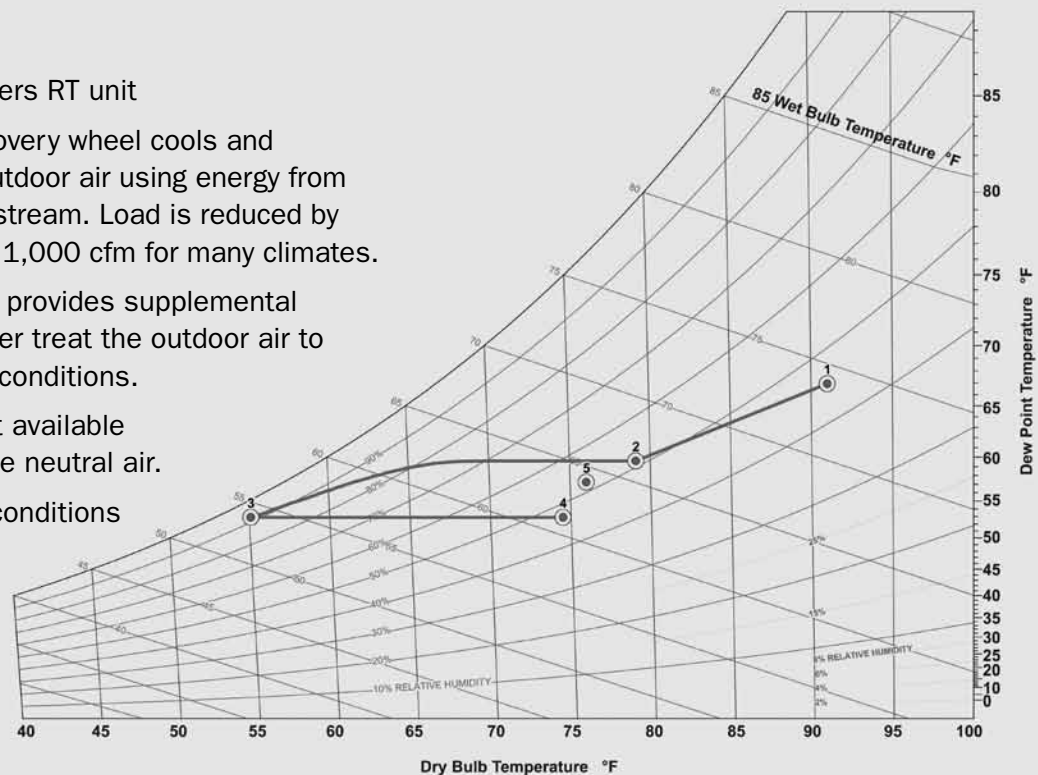

## System Benefits

- **Versatile Application:** FHP RT Series are suitable for diverse applications, for example schools, office buildings, virtually any building requiring ventilation air.
- **Humidity Control:** Ventilate buildings adequately without losing control of indoor humidity levels. The RT is capable of conditioning summer outdoor air to room design conditions. Also, it helps prevent overly dry winter air that can contribute to respiratory irritation.
- **System Design Simplicity:** The RT is designed specifically to provide outdoor air to the space at desired conditions. This effectively de-couples the outdoor air load from the building load.
- **Load Reduction:** The energy wheel saves 3 to 4 tons of cooling and 50-60 MBH of heating for every 1,000 cfm of outdoor air for many climates.
- **Reduced Footprint:** In a water source heat pump system the interior units can be sized only for the space load. This reduces the size of these units and the required air flow

providing additional energy savings and reduced installation costs for the system.

- **Low Maintenance:** Servicing is minimal. All components have a well established history of reliable operation.
- **ASHRAE 62 Compliance:** By assuring that minimum outdoor air volumes are delivered to the room spaces, compliance with the ASHRAE 62 Standard is clearly demonstrated.

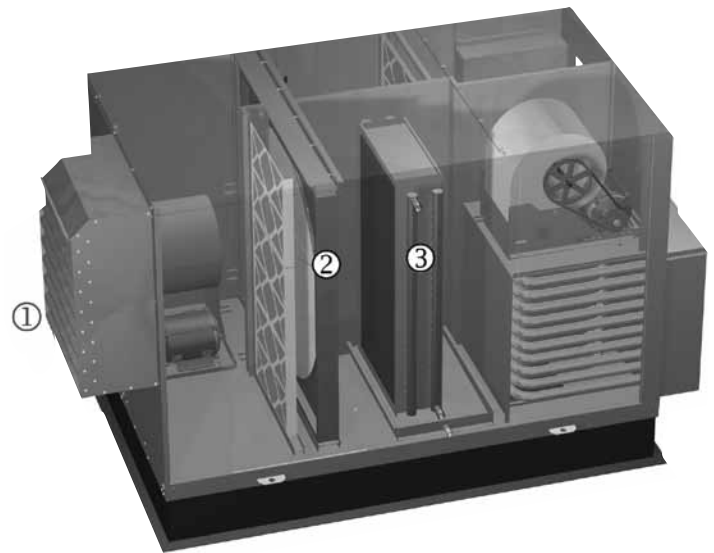

## Heating

1. Outdoor air enters RT unit
2. The energy recovery wheel heats and humidifies winter outdoor air using energy from the exhaust airstream. Heating bills are significantly reduced and overly dry indoor conditions are eliminated.
3. The heat pump provides supplemental heating to further treat the outdoor air to desired supply conditions.
4. Indoor space conditions

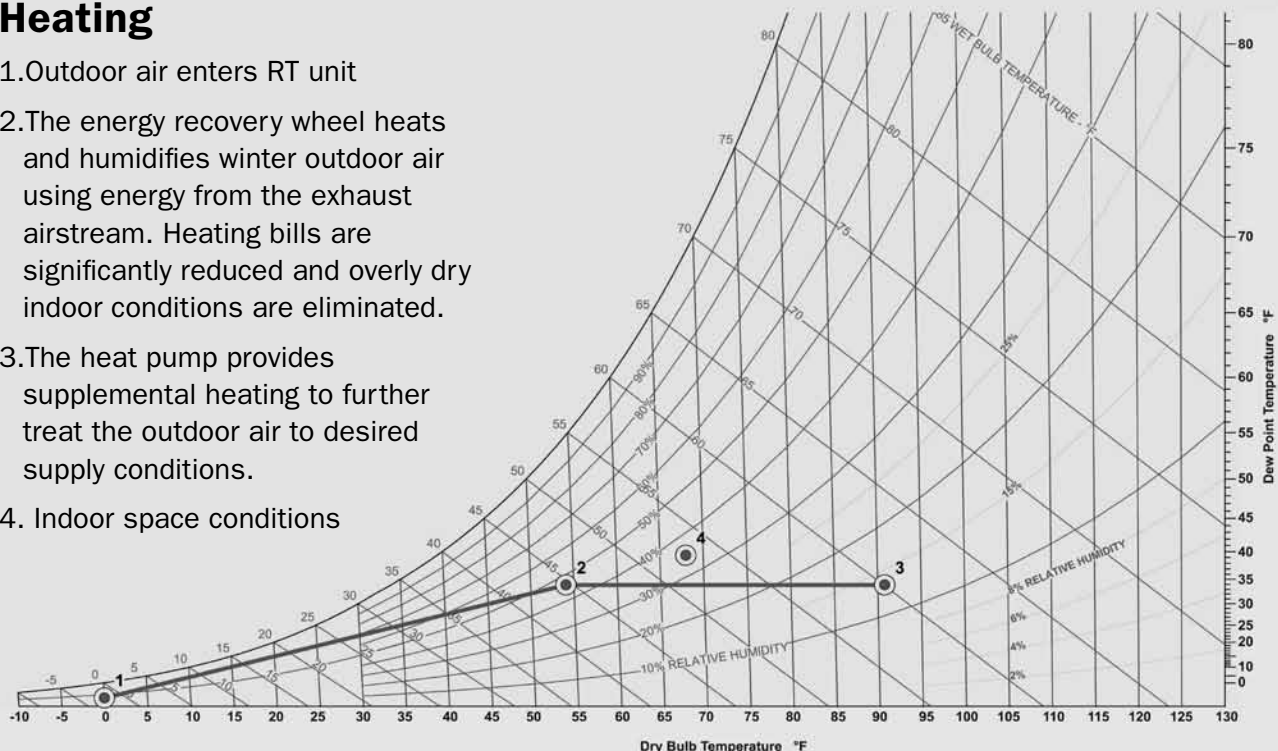



## Unit Features

### Integral Water Source Heat Pump

- Air Side Coils have copper tubes with permanently expanded aluminum fins. Evaporator coils are mounted above a stainless steel drain pan.
- Water Coils are coaxial tube in tube type providing a robust construction less likely to clog and fail than brazed plate heat exchangers.
- Four-way solenoid activated Reversing Valves switch the unit between heating and cooling depending on demand. Units will fail to the heating mode.
- Thermal Expansion Valves provide stable refrigerant control over a wide range of operating conditions.
- Suction line accumulators prevent the possibility of compressor damage due to refrigerant flooding.
- Hot Gas Bypass is standard on the lead circuit preventing icing of the air coil at low-load conditions when in the cooling mode.
- Optional modulating hot gas reheat provides air at neutral conditions to the space when in the cooling mode.
- UPM providing protection for the unit and fault indication.

### Energy Recovery Wheel

- Enthalpy type for both sensible and latent heat recovery. Energy transfer ratings are AHRI Certified to Standard 1060.
- Permanently bonded Silica Gel desiccant for maximum latent energy transfer.
- Removable segments to facilitate cleaning.
- Drive belt material is high strength urethane and installed in a pre-stretched state eliminating the need for field belt tension adjustments.

### Unit Cabinet

- Hinged Access Doors provide easy access to blowers, energy wheel, filters, and coil section for inspection and routine service.

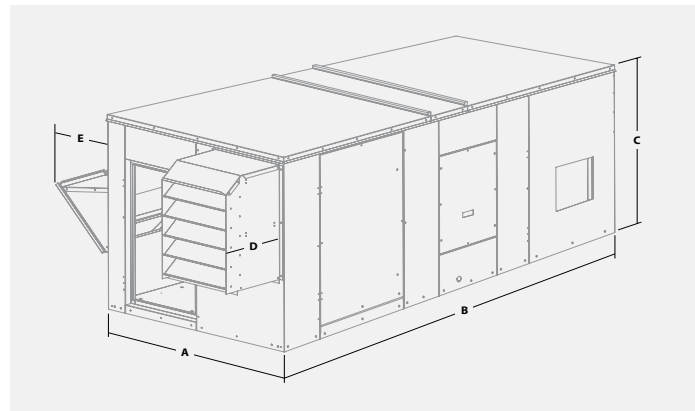

Cabinet Size	Dimensions (in)					Approx. Weight (lb)
	A	B	C	D	E	
RT-20	54.25	108.25	48.75	20.75	17.5	2150
RT-45	64.5	119.25	67	19	15.75	3500
RT-55	75.25	133.5	68.25	23.75	15.75	4450
RT-90	94.5	151.5	83.75	25.5	15.75	6200

Model	Nominal Refrigeration Capacity MBTUH	Cabinet Size	CFM Range
RT048	48	20	1,000 to 2,200
RT060	60		
RT072	72		
RT096	96	45	2,200 to 4,400
RT120	120		
RT150	150		
RT180	180		
RT180	180	55	4,200 to 6,000
RT210	210		
RT240	240		
RT240	240	90	6,000 to 10,000
RT300	300		
RT360	360		

- Single Point Wiring is standard. A disconnect switch and low voltage terminal strip are provided.
- Double Wall Housing is constructed of heavy gauge steel with 1-inch insulation. The supply and exhaust side are internally lined with galvanized steel.
- Control Box is furnished with motor starters for the supply blower, exhaust blower and wheel motors. Also included is a 24 volt control circuit.
- Water connections either internal or external
- Filters are MERV8 on supply and exhaust air streams.

## Fan Sections

- Centrifugal fans are double width, double inlet, forward curved type.
- Bearings rated at a minimum of (L10) life of 100,000 hours.
- Separate motors for supply and exhaust fans.
- Motors are energy efficient complying with EPACK standards.
- Blowers are mounted on neoprene vibration isolators.

## Weather Hoods

A louvered intake hood with 2-inch aluminum mesh filters, and an exhaust hood with an integral back draft damper are available.

## Dampers — Internally Mounted

A variety of motorized control dampers are available. Intake and exhaust dampers are internally mounted at the outdoor and exhaust air inlets. Dampers are factory wired to a single point power disconnect.

## Filters

Standard size 2-inch, MERV 8, pleated, medium efficiency filters and filter racks are available for outdoor air and/or exhaust air streams.

## Frost Control

In cold climates, the recovery wheel may develop frost, which will decrease airflow. Unit shall be equipped with a factory mounted option to address potential frosting:

The preheat frost control enables continuous unit operation. An electric heater warms the outdoor air above the frost threshold before it enters the energy recovery wheel. Control is triggered by the outdoor air temperature set point in conjunction with increased pressure drop across the energy wheel.

## Rotation Sensor

Senses when a wheel rotation failure occurs and sends a signal to an indicator light. The light is available on a remote control panel from the factory.

## Economizer Control (Free Cooling)

When cool outdoor air is available, the energy wheel may be controlled to provide free cooling. Economizer operation can be initiated by the unit sensors alone or in conjunction with a call for cooling (field wired). Two factory installed options are available.

- Wheel Off: De-energizes the wheel when the outdoor temperature is below the field adjustable set point (enthalpy sensor also available). An automatic economizer override is included to engage the wheel for winter heating operation.
- Wheel Modulation: Modulates the energy recovery wheel to maintain a 55°F discharge temperature during economizer operation. Note: Control centers in FHP energy recovery ventilators enable the control of the energy wheel and fans via 24-volt control signals (by others). Controls by others may be preferred when air handling units are equipped with an economizer section.

## Variable Air Volume

Model RT may utilize variable frequency drives (VFDs) for multi-speed or modulating blower control to vary airflows. This shall include a separate VFD for each blower.

## Additional Accessories:

- Remote Panels
- GFCI Service Outlet (control power by others)
- Service Lights (control power by others)
- Spare Wheel Segments
- Roof Curbs
- Painted Exteriors
- Factory Mounted Sensors
- High Filter efficiency option

## Air Performance

The air performance data on page 6 accounts for the pressure drop across the energy recovery wheel and the internal housing losses, but does not include pressure drop for filters or air coil.

Add filter and/or air coil pressure drop (from the tables below) to external static pressure to determine correct rpm and horsepower.

### Filter Pressure Drop (33% eff.)

Model	CFM	Pressure Drop (in. wg)
RT-20	1000	0.04
	2200	0.22
RT-45	2200	0.06
	4400	0.24
RT-55	4200	0.09
	6000	0.18
RT-90	6000	0.10
	10000	0.27

### Tempering Options Pressure Drop

Model	CFM	Pressure Coil (in. wg)
RT-20	1000	0.17
	2200	0.62
RT-45	2200	0.31
	4400	0.66
RT-55	4200	0.38
	6000	0.64
RT-90	6000	0.28
	10000	0.66

## Intake and Discharge Options

With the RT Series, you have many air intake and discharge options available to simplify duct layout for rooftop and equipment room installations. Refer to the table below for the intake and discharge locations available for outdoor air (OA) and exhaust air (EA).

	Bottom	Top	Side	End
<b>OA Intake</b>		X		X
<b>OA Discharge</b>	X	X	X <sup>1</sup>	X <sup>2</sup>
<b>EA Intake</b>	X	X		X
<b>EA Discharge</b>		X	X	X

<sup>1</sup>Side OA Discharge is ONLY available with the Indirect Gas (IG) heater.

<sup>2</sup>End OA Discharge is NOT available with the Indirect Gas(IG) heater.

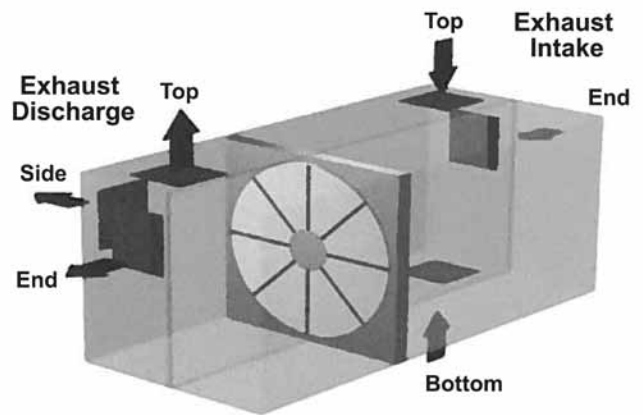
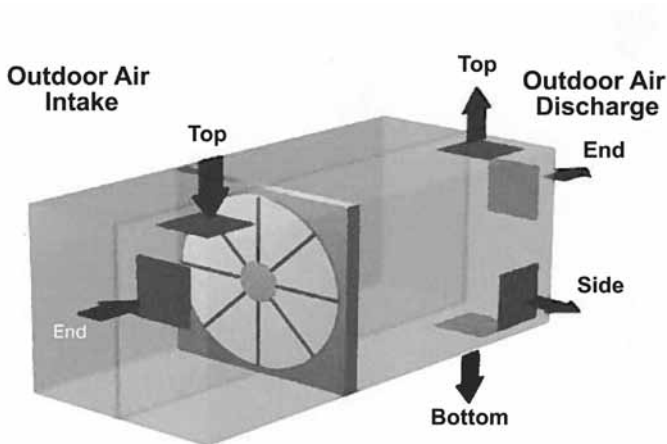

## Air Performance

### RT-20M

CFM	OV		External Static Pressure in inches of wg.							
			0.50	0.75	1.00	1.50	2.00	2.50	3.00	3.50
1000	1142	RPM	1141	1344	1498					
		BHP	0.36	0.51	0.53					
1300	1485	RPM	1265	1426	1578	1857				
		BHP	0.55	0.72	0.90	1.05				
1600	1828	RPM	1418	1553	1684	1934	2189			
		BHP	0.87	1.03	1.21	1.67	2.17			

### RT-20H

CFM	OV		External Static Pressure in inches of wg.							
			0.50	0.75	1.00	1.50	2.00	2.50	3.00	3.50
1600	1828	RPM	1308	1446	1575	1816				
		BHP	0.74	0.89	1.04	1.37				
1900	2171	RPM	1453	1574	1691	1907	2108	2306		
		BHP	1.10	1.27	1.45	1.80	2.19	2.65		
2200	2514	RPM	1608	1717	1820	2020	2205	2375		
		BHP	1.57	1.77	1.96	2.39	2.79	3.20		

### RT-45L

CFM	OV		External Static Pressure in inches of wg.							
			0.50	0.75	1.00	1.50	2.00	2.50	3.00	3.50
2200	2109	RPM	797	892	986	1166	1329			
		BHP	0.68	0.81	0.96	1.29	1.65			
2700	2588	RPM	900	977	1053	1209	1359	1494	1628	
		BHP	1.10	1.25	1.40	1.77	2.18	2.58	3.03	
3200	3068	RPM	1010	1079	1143	1274	1406	1533	1655	1768
		BHP	1.67	1.87	2.04	2.41	2.86	3.33	3.82	4.29

### RT-45H

CFM	OV		External Static Pressure in inches of wg.							
			0.50	0.75	1.00	1.50	2.00	2.50	3.00	3.50
3200	2184	RPM	900	989	1071	1220	1360	1495		
		BHP	1.17	1.34	1.53	1.92	2.35	2.83		
3800	2593	RPM	1004	1083	1157	1297	1422	1542	1654	1769
		BHP	1.79	1.99	2.20	2.64	3.11	3.61	4.12	4.70
4400	3003	RPM	1114	1185	1252	1380	1499	1609	1713	1815
		BHP	2.60	2.85	3.08	3.57	4.09	4.64	5.18	5.78

### RT-55H

CFM	OV		External Static Pressure in inches of wg.							
			0.50	0.75	1.00	1.50	2.00	2.50	3.00	3.50
4200	1989	RPM	749	832	906	1038	1155			
		BHP	1.54	1.82	2.10	2.65	3.21			
5100	2415	RPM	839	913	982	1107	1216	1318	1412	1520
		BHP	2.43	2.77	3.11	3.80	4.45	5.15	5.81	6.73
6000	2842	RPM	940	1003	1065	1181	1287	1382	1472	1558
		BHP	3.67	4.05	4.45	5.26	6.06	6.84	7.64	8.44

### RT-90H

CFM	OV		External Static Pressure in inches of wg.							
			0.50	0.75	1.00	1.50	2.00	2.50	3.00	3.50
6000	2066	RPM	612	682	746	862	962	1058		
		BHP	1.99	2.37	2.75	3.52	4.33	5.21		
8000	2755	RPM	723	783	841	941	1036	1122	1202	1275
		BHP	3.91	4.41	4.95	5.94	6.97	7.98	9.08	10.14
10000	3444	RPM	845	897	946	1040	1124	1201	1277	1348
		BHP	7.00	7.56	8.18	9.5	10.78	12.00	13.29	14.52

## Series RT Energy Recovery Rooftop System Specification

### General:

Packaged Energy Recovery Units shall be fully assembled at the factory. Unit shall be suitable for installation outdoors on a roof and designed to pre-treat 100% outdoor air. Units shall comprise the following sections:

- Water-cooled, reverse cycle heat pump
- Air to Air heat wheel heat recovery
- Filter section in both supply and exhaust sections
- Supply fan
- Exhaust fan

Units shall be UL or ETL Listed. Energy recovery wheel shall be ARI 1060 Certified. Unit shall bear the AMCA Certified Rating seal for Air Performance.

**Unit Casing and Frames:** Unit construction shall be suitable for indoor and outdoor installations. Exterior panels shall be either galvanized, baked enamel or prepainted steel. Unit shall be of internal frame type construction of galvanized steel. Frame and panels shall be G90 galvanized steel. Unit shall be internally lined with galvanized sheet metal creating a double wall. Where top panels are joined there shall be an overlapping, standing seam to insure positive weather protection. All metal-to-metal seams shall be factory sealed, requiring no caulking at job site. Unit base to be designed for curb mounting. Unit base shall overhang the curb for a positive seal against water run-off.

**Weather hoods:** Weather hoods shall be the same finish as the unit. Outdoor air weather hood shall incorporate a louvered design and moisture eliminator. Weather hoods shall be tested in accordance with AMCA Standard 500-L to prevent water penetration up to 3 in/hr at 29 mph.



**Insulation:** Unit casing to be insulated with 1-inch fiberglass. Insulation shall have a maximum flame spread of 25 and smoke developed of 50, when tested in accordance with ASTM C 411. Insulation shall be enclosed in double wall construction and provide full coverage of the entire cabinet including walls, roof and floor.

**Intake and Discharge Options:** Outdoor Air Intake shall be Top or End. OA Discharge shall be Bottom, Top or End. Exhaust Air Intake shall be Bottom, Top or End. Exhaust Air Discharge shall be Top, Side or End.

**Dampers:** Dampers shall be motorized and be wired to a single point power disconnect. Intake and exhaust dampers shall be internally mounted at the air inlet.

**P Trap:** A P trap (condensate drain) assembly shall be provided for each unit, to include cleanout ports, cleanout tool, vacuum break device and see-through reservoir to permit visual verification of water or glycol solution levels.



**Energy Recovery Wheel:** Wheel shall be of the total enthalpy rotary air-to-air type for both sensible and latent energy recovery and be designed to insure laminar flow. Desiccant shall be silica gel for maximum latent energy transfer. Wheel shall be constructed of lightweight polymer media to minimize shaft and bearing loads. Polymer media shall be mounted in a stainless steel rotor for corrosion resistance.

Wheel design shall consist of removable segments for ease of service and/or cleaning. Silica gel desiccant shall be permanently bonded to wheel media to retain latent heat capability after cleaning. Energy recovery drive belt material shall be high strength urethane and shall be factory installed in a pre-stretched state, eliminating the need for field belt tension adjustment. Link style belts are not acceptable.

The entire heat recovery wheel assembly shall be capable of being easily removed for cleaning.

Performance criteria are to be as specified in AHRI Standard 1060, complying with the Combined Efficiency data in the submittal.

**Hinged Access Doors:** All components shall be easily accessible through hinged access doors for exhaust, supply, filter, and damper compartments. Energy recovery wheels (smaller than 58 inches) shall be mounted in a slide-out track for ease of inspection, removal, and cleaning.

**Roof Curbs:** Roof curb to be supplied by unit manufacturer for field assembly. Curb shall consist of die formed galvanized steel sections. Curb shall be full perimeter type with gasketing provided for field installation between curb and unit base.

**Fan Sections:** Centrifugal fans to be double width, double inlet, forward curved type. All blower wheels shall be statically and dynamically balanced. Ground and polished steel fan shafts shall be mounted in



permanently lubricated, sealed ball bearing pillow blocks. Bearings shall be selected for a minimum (L10) life in excess of 100,000 hours at maximum cataloged operating speeds. Separate motors for exhaust and supply blowers shall be provided. Adjustable sheaves on belt-driven fans with motors less than 10 hp shall allow independent balancing of exhaust and supply airflow. Fan and motor assemblies are mounted to heavy gauge galvanized rails with neoprene isolators as standard. Fans shall be located in draw-through position in reference to the energy recovery wheel.

**Motors and Drives:** Motors shall be energy efficient, complying with EPACT standards. Motors shall be permanently lubricated, heavy-duty type, matched to the fan load and furnished at the specified voltage, phase, and enclosure. Drives shall be sized for a minimum of 150% of driven horsepower. Pulleys shall be of the fully machined cast type, keyed and securely attached to the fan wheel and motor shafts; 10 hp and less shall be supplied with an adjustable drive pulley. Energy wheel motors shall have integral overload protection.

Optional Variable Frequency shall be factory installed for modulation of the intake and exhaust blower assemblies. In addition a VFD shall be available for the energy wheel drive motor.

**Filters:** Supply and exhaust air filters shall be MERV 8 2-inch thick pleated fiberglass, tested to meet UL Class 2. Optional combination MERV 8 and MERV 13 pleated fiberglass shall be provided on the outside air stream.

## Heat Pump Module

Modules shall be suitable for a geothermal operation and utilize refrigerant R-410A. All modules shall contain a sealed refrigerant circuit including the following components:

- Hermetic compressor(s) with crankcase heater,
- Balance port expansion valve(s)
- Refrigerant drier(s)
- Refrigerant reversing valve(s)
- Service ports
- Hot gas bypass on circuit one
- Suction line accumulators

Compressor shall be high efficiency scroll, designed for heat pump duty and mounted on rubber vibration isolators. Compressor motors shall be equipped with overload protection. Unit sizes 096 and larger shall have independent dual refrigerant circuits.

Refrigerant reversing valves shall be pilot operated sliding piston type with replaceable encapsulated magnetic coils energized only during the cooling cycle.

All refrigerant lines, except hot gas lines, shall be insulated.

The coaxial water-to-refrigerant heat exchanger shall be constructed as follows:

- Convoluted copper inner-tube and steel outer tube with a designed refrigerant working pressure of 600 PSIG (4125 kPa).
- Designed waterside working pressure of no less than 400 PSIG (2750 kPa).

Safety devices shall include:

- Low pressure cutout set a 40 PSIG (275 kPa) for loss of charge protection (freeze-stat and/or high discharge gas temperature sensor is not acceptable).
- High pressure cutout control set at 600 PSIG (4125 kPa).

Options for heat pump:

- Modulating hot gas reheat
- Cupro-Nickel refrigerant to water coils

## Heat Pump Controls

A control box shall be located within the unit and shall contain a printed circuit UPM control board, controls for compressor, reversing valve, and optional condensate safety sensor and freeze stat. Unit controls shall be 24 volts and shall provide heating or cooling as required by the temperature control system.

The unit-mounted UPM heat pump control system shall have the following features:

- Anti-short cycle time delay on each compressor operation.
- Random start on power up mode.
- Low voltage (Brown Out) interruption protection for each compressor circuit.
- 120-second bypass timer for the low pressure switch.
- Shutdown on high or low refrigerant pressure switch, optional freezestat or condensate sensor.
- Optional freezestat set at 35°F
- Alarm output which closes for remote fault indication, pulsed or constant output based on specific fault (selectable).
- Reset of a unit safety switch at the wall PC or at the main power disconnect.



- Automatic intelligent reset. Unit shall automatically reset the unit twice after a safety shut down before going into a hard lockout.
- Ability to defeat time delays for servicing.
- A LED to indicate safety alarms. The LED shall announce the following alarms: high refrigerant pressure, low refrigerant pressure, low water temperature, or a high level of condensate in the drain pan.

**Cooling Coil:** Direct expansion (DX) coils shall be AHRI Certified and factory tested and rated in accordance with ARI 410. Coils shall have copper tubes with permanently expanded aluminum fins. DX coils shall be equipped with distributors to receive expansion valves at the liquid connections. Dual compressor units shall have interlaced refrigerant circuiting to provide active cooling or heating of the entire face area at part load operation.

**Drain Pans:** Drain pan shall be formed of welded Austenitic stainless steel sheet material and provided with a welded drain connection at the front for connection to a P trap.

**Electrical:** All internal electrical components shall be factory wired for single point power connection. All electrical components shall be UL or ETL Listed, Approved, or Classified where applicable and wired in compliance with the National Electrical Code. Weatherproof, integral door interlocking disconnect switch, motor starters, control circuit fusing, control transformer for 24 VAC circuit, and terminal strip shall be supplied as standard components in the control center. Motor starters consist of a contactor and Class 20 electronic adjustable overload protection and shall be provided for all fan motors.

## Microprocessor Discharge Temperature Control (Optional)

The microprocessor controller is specifically designed and programmed to optimize the performance of an RT unit with supplemental heating and cooling. This option ensures that the outdoor air is conditioned to the desired discharge conditions. The controller and accompanying sensors are factory mounted, wired and programmed. Default settings are preprogrammed, but are easily field adjustable. The microprocessor controller can be interfaced with a Building Management System (BMS) through LonWorks, BACNET, or ModBus.

The unit mounted controller shall be capable of functioning as a stand-alone heating and cooling system controlled by the factory-supplied controllers,

thermostats and sensors or it can be operated as a heating and cooling system controlled by a Building Management System (BMS).

This energy recovery unit shall be controlled by a factory-installed microprocessor programmable controller that is connected to various optional sensors that may have either analog or digital output.

Room display(s) shall be available that function as remote indicators of owner-selected operating parameters and also permit remote input of new operating parameters. Installed location of room display(s) shall be as indicated on the plans.

**Supplemental Hot Water Coil:** Hot water coil shall be factory tested and rated in accordance with ARI 410. Coils shall have copper tubes with permanently expanded aluminum fins, 12 fpi or less.

**Auxiliary Electric Heat:** Electric heat shall be UL listed and circuit fused per NEC over 48 amps. Heater shall be multi-step control, factory wired and installed. Control will be 24 volt with class 2 transformer. Standard air flow switch to shut down heater if air ceases to flow across heater.

## Frost Control

Units shall be equipped with optional frost control to prevent frosting on the energy recovery wheel in sub zero ambient conditions. An electric heater shall preheat outside air prior to entering the heat recovery wheel. The heater control shall be triggered by the outdoor air temperature set point in conjunction with the an increased pressure drop across the energy wheel.

## Rotation Sensor

The unit shall be equipped with an optional wheel rotation sensor. When a wheel rotation failure occurs a signal shall be sent to an indicator light.

## Economizer Control

Units shall be equipped with an optional economizer (free cooling) control. This shall comprise of either:

**Wheel Off:** De-energizes the wheel when the outdoor temperature is below the field adjustable set point or

**Wheel Modulation:** Modulates the energy recovery wheel to maintain a 55°F discharge temperature during economizer operation

## Variable Air Volume Operation

Unit shall be provided with variable frequency drives for modulating or multi speed blower control. A separate VFD shall be provided for each blower motor.

## **Weather Hoods**

A louvered intake hood with 2-inch aluminum mesh filters, and an exhaust hood with an integral back draft damper are available.

## **Dampers — Internally Mounted**

A variety of motorized control dampers are available. Intake and exhaust dampers are internally mounted at the outdoor and exhaust air inlets. Dampers are factory wired to a single point power disconnect.

## **Filters**

Standard size 2-inch, MERV 8, pleated, medium efficiency filters and filter racks are available for outdoor air and/or exhaust air streams.

## **Accessories:**

- Remote Panels
- GFCI Service Outlet (control power by others)
- Service Lights (control power by others)
- Spare Wheel Segments
- Roof Curbs
- Painted Exteriors
- Factory Mounted Sensors
- High Filter efficiency option

# RT ROOFTOP SERIES



601 N.W. 65th Court, Ft. Lauderdale, FL 33309  
Phone: 954-776-5471 | Fax: 954-776-5529  
[www.boschtaxcredit.com](http://www.boschtaxcredit.com) | [www.fhp-mfg.com](http://www.fhp-mfg.com)

